

Datex-Ohmeda
S/5™ Interface Board, B-INT (Rev. 01)
Technical Reference Manual

All specifications are subject to change without notice.

Document No. 8001006-1

June 2001

Datex-Ohmeda Inc.
3030 Ohmeda Drive
53707-7550 MADISON, WIS
USA
Tel. +1-608-221 1551, Fax +1-608-222 9147
www.us.datex-ohmeda.com

Datex-Ohmeda Division,
Instrumentarium Corp.
P.O. Box 900, FIN-00031
DATEX-OHMEDA, FINLAND
Tel. +358 10 394 11 Fax +358 9 146 3310
www.datex-ohmeda.com

© Instrumentarium Corp. All rights reserved.

TABLE OF CONTENTS

Interface Board, B-INT (Rev. 01)

TABLE OF CONTENTS	i
Introduction	1
1 Specifications	2
1.1 Serial I/O definitions.....	2
1.2 Analog definitions.....	2
2 Functional Description	3
2.1 Main components.....	4
2.2 Connectors and signals.....	6
2.2.1 Bus connectors	6
2.2.2 Serial connectors	8
2.2.3 Serial/analog connectors	9
3 Service Procedures	10
3.1 General service information.....	10
3.2 Service check	11
3.2.1 Recommended tools	11
4 Troubleshooting	16
4.1 Troubleshooting chart	16
5 Service MENU	17
5.1 Interface menu	18
6 Spare Parts	20
6.1 Interface Board, B-INT.....	20
7 Earlier Revisions	21
APPENDIX A	23
Service check FORM	A-1

INTRODUCTION

The Interface Board, B-INT, provides an interface between the S/5 Anesthesia Monitor or the S/5 Critical Care Monitor and other monitors. It also provides a connection between the Central Unit, F-CU8, and the Airway Module, G-xxxx.

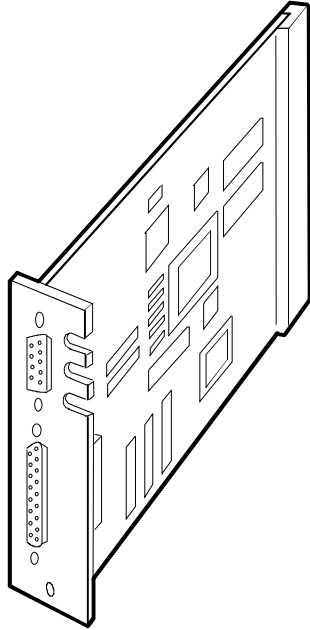

Figure 1 **Interface Board, B-INT**

NOTE: The Interface Board, B-INT, and Interface Module, M-INT, cannot be used simultaneously in the same monitor.

1 SPECIFICATIONS

1.1 Serial I/O definitions

- RS-232 buffered (channels 1-4)
- All standard baud rates are possible from 300 to 115200
- Each interfaced device has fixed baud rate.

1.2 Analog definitions

- There are four analog inputs available on channel 1 and four on channel 2.
- All analog inputs are op-amp buffered, with an input impedance of 1 M Ω . Each analog input is also equipped with a 1 M Ω pull-down resistor to -12 V for NC detection.
- Sampling rate: 10 ms/sample/channel
- Input range: -10 V...+10 V
- Resolution: 10 bits \rightarrow 1024 voltage levels in input range

2 FUNCTIONAL DESCRIPTION

The Interface Board, B-INT, detects and identifies external monitors connected to the S/5 anesthesia or critical care monitoring system. Identification is made by a serial data string sent by the external monitor.

On the front panel of the board there is a 25-pin and a 9-pin D-connector, which are used for sending/receiving digital serial data. The 25-pin D-connector is used for connecting the Airway Module (as the Gas Interface Board is removed when the Interface Board, B-INT is installed).

On the surface of the circuit board there are three pin row connectors, one for digital data and two for digital and analog data. If digital and analog real time waveforms are required, the external monitor can be connected to the serial/analog connectors (X7 and X8) using additional interface connector cables.

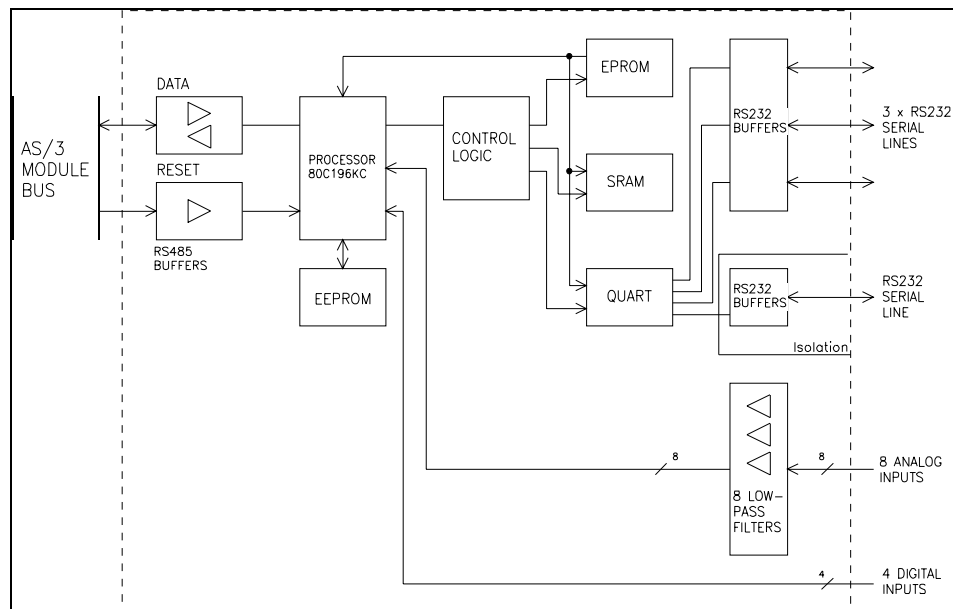

Figure 2 Interface Board, B-INT, block diagram

2.1 Main components

The Interface Board contains an 80C196KC16 CPU.

External connections

The connectors on the board are:

- 96-pin E-connector for the CPU mother board (X1)
- 25-pin D-connector for an Airway Module (X3).
- 9-pin D-connector for RS-232 level isolated serial communications (X2). No analog inputs available.

In addition, three pin-row connectors on the circuit board make the following connections possible using an interface connector cable:

- RS-232 level serial and analog connectors for all interfaces (X7, X8).
- RS-232 level serial digital connector (X9).

X3 and X9 connectors can be used to interface waveforms from Dräger Cato and Cicero external monitors.

The Interface Board is connected to the Central Unit module bus through the CPU mother board.

Serial communication signals for transmitting (TxD) and receiving (RxD) data are sent to the microcontroller ports. The direction of the communication is controlled by REC/SND/ signal at the buffers. The RESET/ signal always resets the communication to the RxD state.

Reset

The Interface Board is reset when the Central Unit is reset (MAIN/RESET/) or when the module bus is reset (RESET_RS485).

The RESET/ signal is sent to an address decoding GAL circuit, from which it goes to the microcontroller as RESET/Z. When the RESET/ is active (low), the RESET/Z also goes low and resets the microcontroller.

Serial communication channels

A QUART is used to provide four serial communication channels (TxD, RxD). The microcontroller is able to reset the QUART at any time by pulling the QRESET signal high. The QUART is also reset when the microcontroller is reset; the microcontroller pulls all the port 1 signals high when it resets.

Memories

There are static RAM, EPROM, EEPROM memories and an address decoding GAL unit on the Interface Board.

The microcontroller communicates with the EEPROM in serial mode.

Digital inputs

Four digital inputs are connected to connector X9 on the Interface Board. They pass through to the microcontroller's high speed pins (DIGBUS). The digital inputs have an overvoltage protection and a pull-up circuit.

Analog inputs

Eight analog inputs are connected to connectors X7 and X8. They pass through EMI filters and low-pass filters to the microprocessor port 0.

Fuse

A 4 A fuse is installed on the Interface Board for the +24/+32 Vdirty input supply. This voltage is not used on the board but passed through to the 25-pin D-connector for Airway Module use.

2.2 Connectors and signals

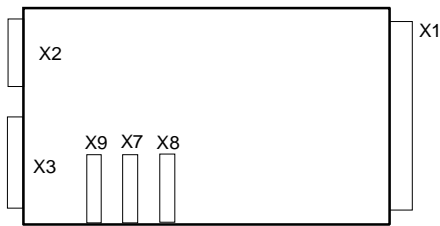

2.2.1 Bus connectors

Module bus connector (X1)

	a	b	c
1	+15 V	AGND	DGND
2	-15 V	BALE	DGND
3	SA0	SA1	DGND
4	SA2	SA3	RESET_RS485
5	SA4	SA5	-RESET_RS485
6	SA6	SA7	DATA_RS485
7	SA8	SA9	-DATA_RS485
8	SA10	SA11	TXDD_RS232
9	SA12	SA13	RXDD_RS232
10	SA14	SA15	BITOIN
11	SA16	SA17	BIT1IN
12	SA18	SA19	TXDC
13	SA20	SA21	RXDC
14	SA22	SA23	RTSC
15	-SMEMR	-SMEMW	CTSC
16	-IOR	-IOW	TXDB
17	CLK	-RESET	RXDB
18	-IOCHRDY	IRQ10	RTSB
19	N/C_1	IRQ11	CTSB
20	N/C_2	IRQ12	TXDA
21	-SBHE	IRQ15	RXDA
22	SD0	SD1	RTSA
23	SD2	SD3	CTSA
24	SD4	SD5	LOUDSPEAKER
25	SD6	SD7	+5 V
26	SD8	SD9	+5 V
27	SD10	SD11	+5 V
28	SD12	SD13	+5 V
29	SD14	SD15	ON/STBY
30	+15 VD	-RESET_CPU	+5 V_CPU
31	+15 VD	+32 VD	REFRESH_WD
32	GNDD	GNDD	POWER_FAIL

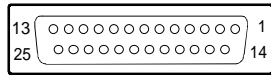
**Airway Module bus connector (X3)**

Pin No	I/O	Signal
1	0	RESET_RS485
2	0	-15 VDC
3	0	+15 VDIRTY
4	0	+15 VDC
5	I/O	-DATA_RS485
6	I/O	DATA_RS485
7		Ground & Shield
8	0	-RESET_RS485
9	0	CTSB
10	I	RTSB
11	0	RXDB
12	I	TXDB
13		Ground & Shield
14	0	+32 VDIRTY
15	0	GroundDIRTY
16	0	CTSC
17	I	RTSC
18	0	RXDC
19	I	TXDC
20		ON/STANDBY
21		BITOIN
22		RXDD_RS232
23		TXDD_RS232
24	0	+5 VDC
25	0	+5 VDC

2.2.2 Serial connectors

Serial connector (X2)

Pin No	I/O	Signal
1		N/C
2	I	RXD RS
3	O	TXD RS
4	O	+5 V
5	O	GND
6		N/C
7	O	RTS RS
8	I	CTS RS
9		N/C

Serial Connector (X9) CH 4 (non-floating, off-board)

Pin No	Definition
1	D0 digital input
2	RXD
3	TXD
4	D1 digital input
5	GND
6	D2 digital input
7	RTS
8	CTS
9	D3 digital input

2.2.3 Serial/analog connectors

Serial/analog connector (X8) CH 1 (non-floating, off-board)

Pin No	Definition
1	A0 analog input
2	RXD
3	TXD
4	A1 analog input
5	GND
6	A2 analog input
7	RTS
8	CTS
9	A3 analog input

Serial/analog connector (X7) CH 2 (non-floating, off-board)

Pin No	Definition
1	A4 analog input
2	RXD
3	TXD
4	A5 analog input
5	GND
6	A6 analog input
7	RTS
8	CTS
9	A7 analog input

Power test connector (X4)

Pin No	Signal
1	+5 Vref
2	+5 V
3	+12 V
4	DGND
5	-12 V
6	NC

Analog test connector

This connector is for factory tests only.

3 SERVICE PROCEDURES

3.1 General service information

A faulty Interface Board, B-INT, should be returned to Datex-Ohmeda for repair.

Datex-Ohmeda is always available for service advice. Please provide the unit serial number, full type designation, and a detailed description of the fault.

CAUTION Only trained personnel with appropriate equipment should perform the tests and repairs outlined in this section. Unauthorized service may void warranty of the unit.

3.2 Service check

These instructions include complete procedures for a service check. The service check is recommended to be performed after any service repair. However, the service check procedures can also be used for determining possible failures.

The procedures should be performed in ascending order.

The instructions include a check form (*Appendix A*) which should be filled in when performing the procedures.

The mark  in the instructions means that the check form should be signed after performing the procedure.

The procedures are designed for monitors with S/5 monitor software of revision 01. However, most of the procedures also apply to monitors, which contain some other monitor software type/revision.

3.2.1 Recommended tools

Tool	Order No.	Notes
Central Unit		
Airway Module		
Datex-Engstrom gas monitor with the SpO ₂ measurement		e.g. ULT-S
INT Interface cable	892377	
Interface connector cable	882353	
Calibration gas		
SpO ₂ probe		
Screwdriver		

- Make sure the S/5 monitor is turned to STBY.
- Press the Service Reset switch at back of the monitor power supply unit for at least five seconds.
- Disconnect all external interface cables connected to the Interface Board, B-INT. Remove the screws securing the Interface Board, B-INT to the Central Unit and remove the Interface Board.

1. Check that the rear panel connectors are clean and intact. Check that the block screws for cables are in place, are tightened properly and their threads are intact.



2. Check all interface connector cables (order code 882353) connected to the Interface Board:
 - the cables are intact and are properly attached with screws
 - the cable connectors are clean and intact
 - the block screws for cables are in place and are tightened properly
 - the block screw threads are intact



3. Check the order of the interface connector cables, if connected:
 - top: connector X8
 - middle: connector X7
 - bottom: connector X9



4. Check that the grounding plate under the rear panel is properly attached and is not bent.

NOTE: Older circuit boards may not include the grounding plate.



5. Check that the screws fastening the interface connector cable metal bracket to the Interface Board rear panel are tightened properly.



6. Check that all socket mounted IC's are inserted properly.



7. Check that the fuse and fuse holder are clean and intact. Check that the fuse is of the correct rating (T4A).



- Connect the interface connector cable to connector X8 on the Interface Board, if not yet connected. Re-install the Interface Board in the Central Unit and secure the board with two screws.
- Connect the Airway Module using a gas interface cable to the Interface Board rear panel connector X2. Connect the Datex-Engstrom gas monitor using the interface cable, order code 892377 (use the gender changer) to Interface Board connector X8 (via the connected interface connector cable).
- Turn both monitors on.
- Make sure the serial output mode of the Datex-Engstrom gas monitor being used is set to NUMERIC.
- Configure the S/5 monitor screen so that all the required parameters are shown, for example:

**Monitor Setup - Screen 1 Setup - Waveform Fields - Field 5 - Pleth
Field 6 - CO₂**

8. Set the interface:

Monitor Setup - Install/Service (password 16-4-34) - **Installation - Interfacing - Gases/Spiro - Module**

and

Monitor Setup - Install/Service (password 16-4-34) - **Installation - Interfacing - Gases/Spiro - SpO₂ - Module**

Check that menus NIBP and SvO₂/C.O. are selectable from the menu.



9. Check that the waveform field for gases is shown on the S/5 monitor screen. When the message "Calibrating gas sensor" disappears, feed calibration gas into the Airway Module sampling line and check that the CO₂ waveform and the gas numerics are shown correctly.



Set the Interface Board for the Datex-Engstrom gas monitor being used:

Monitor Setup - Install/Service (password 16-4-34) - **Installation - Interfacing - Gases/Spiro - XXX**

and

Monitor Setup - Install/Service (password 16-4-34) - **Installation - Interfacing - Gases/Spiro - SpO₂ - XXX**

XXX = the used gas monitor

10. Enter the service menu:

Monitor Setup - Install/Service (password 16-4-34) - **Service** (password 26-23-8)

Take down the information regarding Interface Board software by selecting SCROLL VERS and turning the ComWheel.



11. Enter the B-INT service menu:

Parameters -More...-Interface

Check that the "Timeouts", "Bad checksums" and "Bad c-s by mod" values are not increasing faster than by 50 per second. Check that the B-INT memories have passed the internal memory test, i.e. "RAM" and "ROM" state OK.



12. Check that the interfaced gas monitor is identified, i.e. the required waveform fields are shown on the screen and the gas monitor type is shown correctly on the service menu.

Check that the communication state is "online".



13. Select GASES from the B-INT service menu.

Check that "id:" states the correct monitor and interface type, "Active" states YES and "Timeout" NO.

Check that the numeric values on the service menu are reasonable.

Simulate breathing by feeding calibration gas into the Datex-Engstrom gas monitor sampling line and check that the values on the service menu correspond with the values on the gas monitor screen.

Check that the values in the S/5 monitor gas waveform field are correct and a proper CO₂ waveform is shown.

Stop feeding calibration gas. Check that the message "Apnea" appears in the S/5 monitor waveform field, and in the message field, if the selected interface type is ULT/al.



14. Select SpO₂ from the B-INT service menu.

Check that "id" states the correct monitor and interface type, "Active" states YES and "Timeout" NO.

Check that "ProbeOff" shows 1 when no SpO₂ probe is connected to the interfaced gas monitor. Connect the SpO₂ probe and check that "NoProbe" shows 1.

Attach the SpO₂ probe to your finger and check that the values on the menu correspond with the values on the gas monitor screen.

Check that the values in the S/5 monitor pleth waveform field are correct and a proper pleth waveform is shown.

Disconnect the SpO₂ probe. Check that the message "Probe off " appears in S/5 monitor waveform field, and "SpO₂ probe off" appears in the message field, if the interface type is ULT/al.



15. Turn the gas monitor off. Check that the messages "Interfaced Gas monitor removed" and "Interfaced SpO₂ monitor removed" appear on the S/5 monitor screen.



16. Turn the monitor off. Connect the gas monitor with the interface cable, to Interface Board, B-INT, connector X7 (via the interface connector cable). If necessary, remove the Interface Board, B-INT, for relocating the interface connector cable.

Turn the monitors on and check that the necessary numerics and waveforms are still interfaced, together with the necessary alarms, if the interface type is ULT/al.



17. Turn the monitors off. Connect the gas monitor with the interface cable, to Interface Board, B-INT, connector X9 (via the interface connector cable).

Turn the monitors on and check that only the necessary numerics are interfaced, together with the necessary alarms, if the interface type is ULT/al.



18. Turn the monitors off. Connect the gas monitor with the interface cable, to Interface Board, B-INT, connector X3.

Turn the monitors on and check that only the necessary numerics are interfaced, together with the necessary alarms, if the interface type is ULT/al.



19. Perform an electrical safety check and a leakage current test.



20. Check that the Interface Board, B-INT, functions normally after performing the electrical safety check.



Set the Interface back for modules:

Monitor Setup - Install/Service (password 16-4-34) - **Installation - Interfacing - Gases/Spiro - Module**

and

Monitor Setup - Install/Service (password 16-4-34) - **Installation - Interfacing - Gases/Spiro - SpO₂ - Module**

- Fill in all necessary documents.

4 TROUBLESHOOTING

Enter the Service menu (see chapter 5). Select Scroll Vers and scroll down the SW version/Unit id list. Make sure that the software code and level, control and serial numbers of the Interface Board, B-INT, are displayed under B-INT/M-INT.

If they are not displayed, the Interface Board, B-INT, is faulty.

4.1 Troubleshooting chart

Trouble	Cause	Treatment
B-INT not active in the <i>Service</i> menu.	B-INT is not connected properly. B-INT is faulty.	Check that B-INT is firmly pushed into the connector. Replace B-INT and send it for repair.
Measured values from the interfaced monitor do not appear on the display after approximately one minute.	Monitor not selected for interface. Poor contact in the interface cables. Wrong interface cable.	Select correct monitor from <i>Install/Service - Interfacing</i> menu. Check the cables and connections. Change the cable to another connector. Check cable type and if necessary change the cable.

5 SERVICE MENU

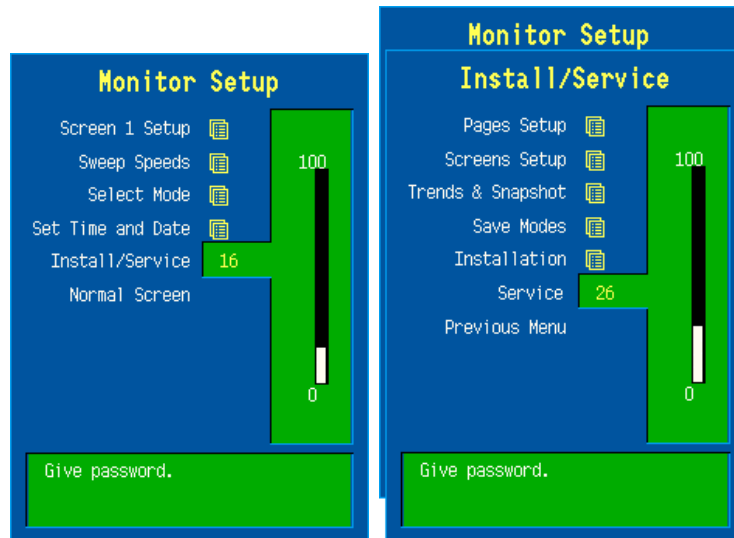

1. Press the **Monitor Setup** key.
2. Select ***Install/Service*** (password 16-4-34).
3. Select ***Service*** (password 26-23-8).
4. Select ***Parameters***.
5. Select ***More...***
6. Select ***Interface***.

5.1 Interface menu

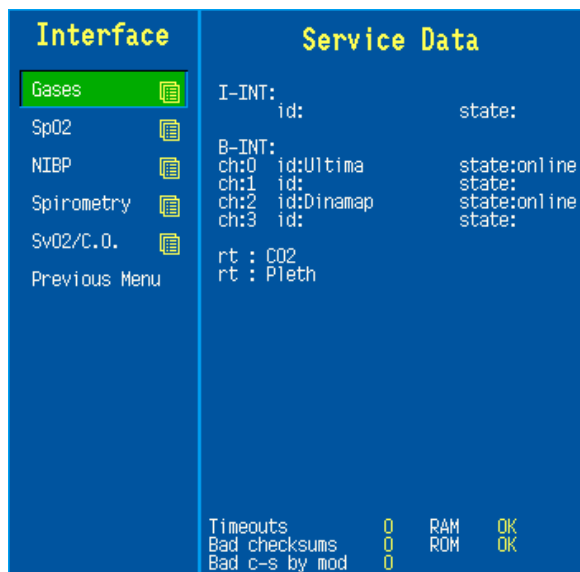

Interface

Gases, SpO₂, NIBP, Spirometry, SvO₂ / C.O. indicate the parameters for which service data is available. The data which can be seen on those pages is raw data from the interfaced monitors, which will be processed for the normal screen.

Service Data

- I-INT** Indicates the status of the interface via the UPI Board.
- B-INT** Indicates the status of the interface via the 4 interface channels of Interface Board, B-INT.
- id:** The name of the interfaced monitor, e.g. Ultima.
- state:** describes the state of the connection, alternatives are:
 'init ' - the channel is initialized
 'wait ' - the monitor is waiting for the external monitor
 'online' - the connection is ready
 'search' - the external monitor is being searched.
- rt:** real time values that are available via the interface.

Timeouts is a cumulative number that indicates how many times the module has not responded to the monitor's inquiry.

Bad checksums is a cumulative number that indicates how many times communication from the module to the monitor has failed.

Bad c-s by mod is a cumulative number that indicates how many communication errors the module has detected.

The monitor starts counting these items at power up and resets to zero at power off. The nonzero values do not indicate a failure, but a continuous counting (more than 50 per second) indicates either serial communication failure, or module not in place. Also other modules can cause communication errors which cause these numbers rise.

RAM indicates the state of the RAM memory.

ROM indicates whether the checksum in the EPROM is in accordance with the software calculated value.

The state is either **OK**, **Fail** or **?** (module not in place or a communication error).

6 SPARE PARTS

NOTE: Accessories are listed in the *Patient Monitor Supplies and Accessories*.

6.1 Interface Board, B-INT

Item	Description	Order No.
	Fuse T4A	*51134
	Grounding plate	885404
	Block screw for cables	546096
	Interface connector cable	*882353

* This part is recommended for stock

7 EARLIER REVISIONS

This manual also supports Interface Board, B-INT (rev. 00).

APPENDIX A

SERVICE CHECK FORM

Interface Board, B-INT

Customer	_____		
Service	_____	Board type	_____ S/N _____
Service engineer	_____	Date	_____



OK = Test OK



N.A. = Test not applicable



Fail = Test Failed

	OK	N.A.	Fail		OK	N.A.	Fail
1. Rear panel connectors	<input type="checkbox"/>	<input type="checkbox"/>	<input type="checkbox"/>	2. Interface connector cables	<input type="checkbox"/>	<input type="checkbox"/>	<input type="checkbox"/>
3. Cable order	<input type="checkbox"/>	<input type="checkbox"/>	<input type="checkbox"/>	4. Grounding plate	<input type="checkbox"/>	<input type="checkbox"/>	<input type="checkbox"/>
5. Metal bracket attachment	<input type="checkbox"/>	<input type="checkbox"/>	<input type="checkbox"/>	6. IC attachment	<input type="checkbox"/>	<input type="checkbox"/>	<input type="checkbox"/>
7. Fuse	<input type="checkbox"/>	<input type="checkbox"/>	<input type="checkbox"/>				
Notes	_____						

8. Interface selection	<input type="checkbox"/>	<input type="checkbox"/>	<input type="checkbox"/>	9. Airway module interface (X2)	<input type="checkbox"/>	<input type="checkbox"/>	<input type="checkbox"/>
10. Module software	B-INT						
11. Communication and memories	<input type="checkbox"/>	<input type="checkbox"/>	<input type="checkbox"/>	12. Recognition of connection	<input type="checkbox"/>	<input type="checkbox"/>	<input type="checkbox"/>
13. Gas interface (X8)	<input type="checkbox"/>	<input type="checkbox"/>	<input type="checkbox"/>	14. SpO ₂ interface (X8)	<input type="checkbox"/>	<input type="checkbox"/>	<input type="checkbox"/>
15. Recognition of disconnection	<input type="checkbox"/>	<input type="checkbox"/>	<input type="checkbox"/>	16. Interfacing (X7)	<input type="checkbox"/>	<input type="checkbox"/>	<input type="checkbox"/>
17. Interfacing (X9)	<input type="checkbox"/>	<input type="checkbox"/>	<input type="checkbox"/>	18. Interfacing (X3)	<input type="checkbox"/>	<input type="checkbox"/>	<input type="checkbox"/>
Notes	_____						

19. Electrical safety	<input type="checkbox"/>	<input type="checkbox"/>	<input type="checkbox"/>	20. Functioning after electrical safety check	<input type="checkbox"/>	<input type="checkbox"/>	<input type="checkbox"/>
-----------------------	--------------------------	--------------------------	--------------------------	---	--------------------------	--------------------------	--------------------------

Notes _____

Used Spare Parts _____

Signature _____
