

moblvac III



OPERATOR/MAINTENANCE
M A N U A L



Air and Vacuum Specialists

AEROS INSTRUMENTS, INC.

MULTIPURPOSE SUCTION UNIT



**MEDICAL EQUIPMENT CLASSIFIED BY
UNDERWRITERS LABORATORIES INC.
WITH RESPECT TO ELECTRIC SHOCK,
FIRE, MECHANICAL AND OTHER HAZARDS
ONLY IN ACCORDANCE WITH UL 2601-1,
AND CAN/CSA C22.2 NO.601.1**



**ATTENTION, CONSULT ACCOMPANYING
DOCUMENTS**



TYPE B EQUIPMENT

1. Protection against electric shock (5.1, 5.2) Class I, type B equipment.
2. Protection against harmful ingress of water (5.3) ordinary equipment
3. Degree of safety in the presence of a flammable anesthetics or oxygen.

**NOT SUITABLE FOR USE IN THE PRESENCE OF
FLAMMABLE ANESTHETICS OR OXYGEN.**

4. Mode of operation (5.6). Models 757000 and 767000 - continuous; Models 756000 and 766000 - intermittent and continuous.

The purpose of the Moblvac III is to perform all routine suctioning procedures. These may include tracheal and oral aspiration, wound drainage, gastrointestinal, and thoracic drainage.

The Aeros Moblvac III is a multipurpose suction unit designed for general use in the hospital, surgery center, and physicians offices. Because of the Moblvac III's capacities, it can also be utilized as a back up to wall vacuum system. The Moblvac's constant and intermittent suction capabilities are driven by a fan cooled, rotary carbon vane pump. It comes equipped with a disposable exhaust filter, an inline suction filter with 14" of tubing, a disposable 1200cc collection canister with mounting bracket, and a preventative maintenance kit.

This manual covers Moblvac III in the following sections:

1.	INSTRUCTIONS FOR USE.....	Page 3
2.	MAINTENANCE	Page 7
3.	PERFORMANCE TEST & ADJUSTMENTS.....	Page 11
4.	TROUBLESHOOTING	Page 13
5.	DEVICE SPECIFICATIONS	Page 15
6.	DETAILED DRAWINGS.....	Page 16

If, after reading this manual you require additional information, please contact Aeros Instruments' Customer Service Department at 800-662-5822 or your local Aeros distributor.

1. INSTRUCTIONS FOR USE

IMPORTANT: This device is for use only by persons properly trained in medical suction techniques and in the operations of suction equipment. Improper use could cause injury. Thoroughly read this operations manual to familiarize yourself with the Moblvac III before using the device.

DANGER: POSSIBLE EXPLOSION HAZARD IF USED IN THE PRESENCE OF FLAMMABLE ANESTHETICS.

PRIOR TO INITIAL USE

Upon receiving your new Moblvac III, perform the following initial tests to ensure that your unit is in good working order and that no damage has occurred during shipment.

SET UP INSTRUCTIONS

1. Visually inspect all components for physical damage that may have occurred during shipping.
2. After removing all components from their cartons, insert the backpole assembly into the back of the Moblvac III base.
3. Align the two "collection mounting brackets" located at the top of the backpole assembly towards the front of the unit.
4. Tighten the 5/32" screw located at the back of the base assembly.
5. Connect the tubing from the bottom of the backpole to the safety overflow trap assembly.
6. Plug the power cord into an electrical outlet. Depress the "POWER" switch and listen to verify that the pump starts.
7. Verify that both vacuum ports, located at the top of the backpole, are pushed down in the "OFF" position.
8. Switch the unit to "CONSTANT" suction with the "MODE SELECTION" switch.
9. Adjust the vacuum level by turning the vacuum regulator knob. Verify that the vacuum gauge reflects a change in vacuum level while turning the regulator knob.
10. Depress the "POWER" switch to turn the unit OFF (O).

NOTE: 220V unit comes with a detachable power cord. Attach power cord to the appliance outlet located on the bottom of the unit before plugging unit in.

11. Place a collection canister bracket (ring) in the mounting bracket of the backpole assembly or pedestal stand and insert a collection canister.

The Moblvac III will use any collection device. However, if you are not using an Aeros 1200cc disposable collection canister, make sure that the collection device that is being used is equipped with a safety overflow mechanism to protect the pump from accidental overflow.

Ensure that you have the appropriate collection device and suction tubing. Depending on the procedure, be sure that to have the appropriate Chest Drainage Unit, Nasal Gastroic tube, aspirating tip, or wound drain for patient use. The Moblvac III is now ready to place into service.

OPERATING INSTRUCTIONS

Verify that a clean bacteriostatic exhaust filter, in line suction filter, collection canister, and the necessary tubing are installed on the Moblvac III.

ORAL, NASAL AND TRACHEAL ASPIRATION

1. Place a clean collection canister in the upper bracket, located on the backpole assembly of your Moblvac III. Ensure that tubing is connected from the "DUAL VACUUM PORT ASSEMBLY" of the Moblvac III to the "vacuum port" of the collection canister and from the "patient port" of the collection canister to the aspirating tip that is being used.
2. Verify that both vacuum ports located on the "DUAL VACUUM PORT ASSEMBLY" are pushed down, in the "OFF" position.
3. Turn the Moblvac III ON (I).
4. Switch the unit to "CONSTANT" suction with the "MODE SELECTION" switch.
5. Adjust the vacuum to the desired vacuum level by using the "VACUUM REGULATOR" knob.
6. Open the appropriate vacuum port of the "DUAL VACUUM PORT ASSEMBLY" by pulling out the release knob and proceed with the suction procedure.

NASOGASTRIC INTERMITTENT SUCTIONING.

1. Place a clean collection canister in the upper bracket, located on the backpole assembly of your Moblvac III. Ensure that tubing is connected from the "DUAL VACUUM PORT ASSEMBLY" of the Moblvac III to the "vacuum port" of the collection canister and from the "patient port" of the collection canister to the Nasogastric tube that is being used.

2. Verify that both vacuum ports located on the "DUAL VACUUM PORT ASSEMBLY" are pushed down, in the "OFF" position.
3. Turn the Moblvac III ON (I).
4. Switch the unit to "CONSTANT" suction with the "MODE SELECTION" switch.
5. Adjust the vacuum to the desired vacuum level by using the "VACUUM REGULATOR" knob.
6. Switch the unit to "INTERMITTENT" suction with the "MODE SELECTION" switch.
7. Open the appropriate vacuum port of the "DUAL VACUUM PORT ASSEMBLY" by pulling out the release knob and proceed with the suction procedure.

PLEURAL DRAINAGE

Moblvac III can be utilized with any "Disposable Chest Drainage Unit" available on the market. Some chest drainage units come with a built in flow adjustment valve and some do not. The Aeros Needle Valve Assembly is available for those units that do not offer this feature.

Follow all manufacturers' directions on the Chest Drainage Unit for its setup and use.

Chest Drainage Units Without Built In Flow Adjustment Valves.

Place the Chest Drainage Unit in the "optional" Aeros Chest Drainage Unit Bracket. Ensure that tubing is connected from the "DUAL VACUUM PORT ASSEMBLY" of the Moblvac III to the Aeros Needle Valve Assembly which is mounted in the collection canister bracket of the backpole. Connect tubing from the Needle Valve Assembly to the vacuum port tubing of the Chest Drainage Unit.

OR

Chest Drainage units With Built In Flow Adjustment Valves.

Place the Chest Drainage Unit in the "optional" Aeros Chest Drainage Unit Bracket. Ensure that tubing is connected from the "DUAL VACUUM PORT ASSEMBLY" of the Moblvac III to the vacuum port tubing of the Chest Drainage Unit.

1. Verify that both vacuum ports located on the "DUAL VACUUM PORT ASSEMBLY" are pushed down, in the "OFF" position.
2. Turn the Moblvac III ON (I).
3. Switch the unit to "CONSTANT" suction with the "MODE SELECTION" switch.
4. Adjust the Moblvac III to a low vacuum setting by using the "VACUUM REGULATOR" knob.

NOTE: The vacuum level provided to the chest cavity is regulated by the **Chest Drainage Unit**. Setting the **Moblvac** to a low vacuum level ensures that you are producing sufficient vacuum to properly operate the chest drainage unit.

REPROCESSING AND CLEANING INSTRUCTIONS

1. **Discard all contaminated parts after any suctioning procedure. These components may include the collection canister, disposable chest drainage unit, in-line filter, exhaust filter, and all suction tubing.**
2. **Wipe the surface of the unit clean with a mild antiseptic and a clean soft cloth.**
3. **Place a new collection canister, suction tubing, and filters with the Moblvac III.**
4. **Check the air inlet filter at the back of the unit to see that it is clear of any dirt. If cleaning is necessary, vacuum the filter or, if dirt is excessive, wash in a mild antiseptic and thoroughly rinse in water. After the filter is completely dried, reinstall the filter.**
5. **Inspect the overflow trap assembly for any evidence of an accidental overflow. If an overflow has occurred, use the following guidelines.**

OVERFLOW - Aspirant has contaminated the overflow trap assembly. Replace and/or clean parts according to procedures described in **OVERFLOW CLEANING PROCEDURE** below.

SEVERE OVERFLOW - Aspirant has contaminated the overflow trap assembly and the vacuum port tubing. Replace and/or clean external parts according to procedure described in **OVERFLOW CLEANING PROCEDURE** below. In addition, open the unit to assess the extent of the internal overflow.

OVERFLOW CLEANING PROCEDURE

NOTE: THESE PROCEDURES ARE ONLY REQUIRED WHEN AN OVERFLOW HAS OCCURRED.

1. **Discard all external contaminated tubing.**
2. **Clean the overflow trap assembly by unscrewing the cap and disassembling the various components. Wash all parts with mild antiseptic, dry, reassemble and verify that the float is in the down position and the cap seals tightly on the glass jar.**

3. Replace all discarded tubing.
4. If the vacuum port tubing was contaminated, open the unit and inspect the following parts for contamination (see MAINTENANCE section below for opening the unit):

All Internal Tubing: If contaminated, replace.

Regulator Assembly: If contaminated, clean according to procedure on page 8.

Solenoid Manifold Assembly: If contaminated, clean according to procedure on page 8.

Pump Assembly: If contaminated, clean according to procedure on page 10.

2. MAINTENANCE

Tools required to service the Moblvac III.

- | | |
|--------------------------|--------------------------|
| (1) Pliers | (1) Phillips screwdriver |
| (1) 11/32" nut driver | (1) 5/64" Allen wrench |
| (1) Adjustable wrench | (1) 1/16" Allen wrench |
| (1) Flathead screwdriver | |

CAUTION: NEVER DISASSEMBLE THE MOBLVAC III WHEN THE POWER CORD IS CONNECTED TO AN ELECTRICAL OUTLET.

To access the internal components of the Moblvac III, remove the two (2) Phillips head screws located in the rear of the unit near the back assembly. Tilt the cover forward.

PREVENTATIVE MAINTENANCE

Preventative maintenance is recommended every six months. It is up to the user's discretion to clean the unit more often after frequent use or to lengthen the schedule if use is infrequent.

Preventative Maintenance Kit is available which contains all necessary items and instructions for performing the preventative maintenance procedure.

VACUUM REGULATOR REPLACEMENT

1. Tilt the shroud assembly forward off of the Moblvac III base (make note of the orientation of all tubing and the regulator body).
2. Disconnect all three (3) tubing connections from the regulator body.
3. Use a 5/64" Allen wrench to loosen the set screw on the shaft of the regulator body. Unscrew and remove the vacuum regulator knob from the control panel.

4. Remove the outside locknut that secures the regulator to the control panel. The regulator can now be removed. (**Please note:** the depth of the inside locknut on the shaft of the regulator body. This determines the height of the regulator body in the control panel).
5. To mount the new regulator, first remove the knob from the body by loosening the set screw on the shaft of the body. (Use a 5/64" Allen wrench).
6. Mount the new regulator body to the control panel making sure the fittings are in the same orientation as the original.
7. Insert the regulator knob fully into body.
8. Tighten the set screw until it stops. Then loosen the set screw a 1/4 turn to prevent damage to the shaft of the knob.
9. Reconnect all tubing.

VACUUM REGULATOR CLEANING

1. Remove the vacuum regulator assembly as described in the VACUUM REGULATOR REPLACEMENT on page 7.
2. Discard all tubing.
3. Remove the O-rings from the knob. Also, note that the inner rod of the knob can be pulled out for cleaning.
4. Clean the body, fittings and O-rings in a mild soap solution or isopropyl alcohol and dry all parts completely. Clean only the shaft and the removable inner rod on the regulator knob. Do not allow any water into the knob as it will impede its performance.
5. Reassemble all components and apply a light coating of a silicone based lubricant (i.e.: Dow Corning 111) to the O-rings.
6. Reassemble the vacuum regulator and remount the regulator in the Moblvac III.
7. Attach new vacuum tubing.

SOLENOID MANIFOLD REPLACEMENT

1. From the inside of the Moblvac III base, locate and remove (4) 11/32" nuts that hold the chassis into the base.
2. Disconnect the three (3) wires from the power cord assembly.

3. Disconnect the four (4) wires from the solenoid to the Printed Circuit Board.
4. Disconnect the tubing from the solenoid manifold and the long tubing from the vacuum regulator.
5. Without disconnecting any of the switch wires, carefully lift the chassis up and rest the chassis on its side in the base.
6. Locate the two (2) Phillips screws on the underside of the chassis that secure the solenoid manifold in place and remove them. Remove the solenoid manifold.
7. Mount the new solenoid manifold by securing the two Phillips screws on the underside of the chassis.
8. Mount the chassis back in the Moblvac base.
9. Reconnect all tubing.
10. Reconnect the four (4) wires from the solenoids to the Printed Circuit Board and the three (3) wires from the power cord assembly.
11. Proceed to page 11 for PERFORMANCE TEST & ADJUSTMENTS to set vacuum & flow.

SOLENOID MANIFOLD CLEANING

1. Remove the solenoid assembly as described in the solenoid manifold replacement section.
2. Using a flat head screwdriver remove both solenoids from the manifold.
3. Loosen the set screw (located on the top of the manifold block) and remove the needle adjustment valve.
4. Remove and disassemble the relief valve and check valve assembly from the solenoid manifold.
5. With a cotton swab and an isopropyl alcohol solution, clean all internal areas of the manifold, check valve, relief valve, and flow adjustment valve.
6. After thoroughly drying all parts, reassemble the solenoid manifold. **Please note:** make sure upon reinstallation the internal diaphragm for the check valve is facing away from the solenoid manifold.
7. Proceed to page 11 for PERFORMANCE TEST & ADJUSTMENTS to set vacuum & flow.

PUMP REPLACEMENT

1. Disconnect the three (3) pump wires from the PCB and two (2) wires from the capacitor.
2. Disconnect the tubing from the fittings on the pump.
3. If necessary, loosen the mounting bracket for the capacitor and remove the capacitor.
4. Using an 11/32" nut driver, remove the four (4) nuts from the base of the pump. Remove pump.
5. To mount replacement pump, insert the pump onto the four (4) vibration bumper posts and secure the pump in place.
6. Replace the capacitor and secure the mounting bracket.
7. Connect the pump wires to the PCB and the capacitor.
8. Reconnect all tubing.
9. Proceed to PERFORMANCE TEST & ADJUSTMENTS on page 11.

PUMP CLEANING

NOTE: The heart of the Moblvac III is a rotary carbon vane pump. It is NOT recommended that the pump be disassembled for routine cleaning. However, if performance has been affected by the pump becoming contaminated with aspirant, or if an overflow problem has occurred, the following procedure should be performed.

1. Remove the pump assembly from the Moblvac III as described above in the PUMP REPLACEMENT section.
2. Remove the three (3) pump head screws located on the pump head.
3. Remove the cover plate, shim, wear plate and the four (4) vanes.
4. Wash all exposed areas with an isopropyl alcohol solution.

NOTE: Before you reassemble the pump make certain that all components are completely dry. Rust is likely to form if any moisture is present.

5. Replace the vanes, wear plate, shim, and cover plate.
6. Replace and equally tighten the three (3) pump head screws.
7. Reinstall the pump assembly.

3. PERFORMANCE TEST AND ADJUSTMENT

The Moblvac III's maximum vacuum on both "Constant/Intermittent" and the flow rate on "Intermittent" are present at the factory. Due to various circumstances, readjusting these levels may be necessary. It is recommended that you verify the specifications and the performance of the Moblvac III after:

- An overflow.
- Preventative maintenance.
- Any maintenance.

To verify pump & regulator operation:

1. Plug the power cord into an electrical outlet. Turn the unit **ON (I)** and listen to verify that the pump starts.
2. Open one of the vacuum outlets located at the top of the backpole assembly and place your finger over the outlet.
3. Switch the unit to "CONSTANT" with the "MODE SELECTION" switch.
4. Adjust the vacuum level by turning the vacuum regulator knob. Verify that the vacuum gauge reflects a change in vacuum level while turning the regulator knob. Also verify that you feel vacuum at your finger tip.
5. Turn the unit **OFF (O)**.

The following steps will verify the flow and the vacuum specifications:

1. Connect the Aeros Vac-U-Test® or any other suction flow measuring device to the vacuum outlet of the Moblvac III.
2. Turn the unit **ON (I)**.
3. Adjust the Moblvac III to full vacuum and verify that both the flow and vacuum specifications match the figures found on page 15 of this manual.

To adjust the vacuum level, locate the vacuum relief valve on the solenoid manifold.

1. Turn the relief body (large knurled knob) counterclockwise to loosen while turning the locking ring (small knurled ring) clockwise. Do not remove the relief body, only loosen.
2. With a vacuum testing device attached to the vacuum outlet (located at the top of the backpole), turn the unit **ON (I)**. Switch to "CONSTANT" suction and adjust the vacuum regulator knob, located on the control panel to full vacuum.
3. Slowly turn the relief body until you reach the vacuum specification found on page 15 of this manual. Once the desired vacuum level has been reached, and while holding the relief body in place, turn the locking ring counterclockwise until it locks the relief body in place.

To adjust the flow level for intermittent, locate the flow adjustment valve on the end of the solenoid manifold. There is no adjustment to be made for the flow level on "CONSTANT".

1. With a flow testing device attached to the vacuum outlet, turn the unit ON (I). Switch to "INTERMITTENT" suction and adjust the vacuum regulator knob, located on the control panel to full vacuum.
2. With a 1/16" Allen wrench, loosen the set screw. Turn the flow adjustment valve until you reach the flow specification found on page 15 of this manual. Tighten the set screw.

4. TROUBLESHOOTING

PROBLEM	CAUSE	CORRECTION
Low or no vacuum on running unit.	<ol style="list-style-type: none"> 1. Regulator is turned all the way off. 2. An improper tubing connection or crimped tube in the system. 3. Mechanical shut-off is activated in either the overflow trap assembly or the collection canister. 4. Vacuum ports (Dual Vacuum Port) are turned OFF. 5. Collection canister improperly installed or defective. 	<ol style="list-style-type: none"> 1. Turn regulator knob clockwise to start flow or increase vacuum 2. Check all external vacuum parts for crimped tubing. If still no vacuum check all internal tubing connections. 3. If mechanical shut-off has been activated on a full canister, replace the canister. If the overflow trap assembly has been activated in the safety overflow jar. Follow <u>Overflow Cleaning Procedures</u> on page 6. 4. Open vacuum outlet on the "Dual Vacuum Port". 5. Check canister for any cracks. Verify that all ports on the canister lid are tight.
Pump does not turn on when power switch is depressed.	<ol style="list-style-type: none"> 1. Unit is not plugged in. 2. Faulty electrical connections. 3. Pump has seized. 4. The motor may be worn and cannot deliver the torque required to operate the pump, or the bearing is damaged and is locking the rotor in place. 5. Blown fuse (s). 	<ol style="list-style-type: none"> 1. Plug the unit into an outlet. 2. Make sure that all wires are secured tightly on the lugs and the lugs themselves are secured on the terminals. 3. Clean pump according to <u>Pump Cleaning</u> on page 10. 4. Replace the pump. 5. Replace fuse (s). Also check #3 above.
Low or no flow on INTERMITTENT mode.	<ol style="list-style-type: none"> 1. Faulty MODE SELECTION switch or its electrical connections. 2. Faulty 3-way solenoid on manifold. 3. Flow adjustment valve for intermittent flow is set OFF or too low. 	<ol style="list-style-type: none"> 1. Check that all wires are connected properly or replace switch. 2. Check that the 3-way solenoid is operating properly. 3. Adjust flow rate according to the directions found on page 12.
High flow on INTERMITTENT mode.	<ol style="list-style-type: none"> 1. Flow adjustment valve for intermittent flow is set too high. 2. Faulty 2-way solenoid on manifold. 	<ol style="list-style-type: none"> 1. Adjust the flow rate according to the directions found on page 12. 2. Check that 2-way solenoid is operating properly.

PROBLEM	CAUSE	CORRECTION
Gauge does not register vacuum level.	<ol style="list-style-type: none"> 1. Gauge is either not connected or is faulty. 2. Blockage in vacuum lines. 	<ol style="list-style-type: none"> 1. Check that tubing is properly connected between vacuum regulator and gauge. 2. Check that the 2-way solenoid is not stuck in the open position; or Check Valve is not stuck closed; or that the vacuum regulator is not completely turned off.
High noise level.	<ol style="list-style-type: none"> 1. Unit enclosure is not properly closed. 2. Pump is running at high pitch. 3. Loose fittings on the exhaust side of the pump. 	<ol style="list-style-type: none"> 1. Check that the unit is properly closed. Verify that the outer flanges of the edge trim are not stuck between the enclosures. 2. Replace the vanes and clean the pump or replace entire pump. 3. Check all fittings on the exhaust side of the pump for any loose connection.

5. DEVICE SPECIFICATIONS

PUMP

Rotary Carbon vane type.

PERFORMANCE

Vacuum Range: 0-380mm Hg

Free Air Flow: 34 LPM minimum (constant mode)
8 LPM (intermittent mode)

CONTROLS

Vacuum Regulator: Rotary type on panel.

Vacuum Gauge: Calibrated to 0-300mm/15" Hg

ELECTRICAL REQUIREMENTS

AC: 120V, 60Hz, 3A
220V, 50Hz, 2A

Fuses: Slow blow.

110 VAC



MEDICAL
EQUIPMENT
LISTED
544U

COLLECTION DEVICE

Canister: Disposable plastic with mechanical shutoff.

Capacity: 1200cc standard.

Tubing: 14" with bacterial filter.



22.2 NO. 125

PHYSICAL DIMENSIONS

Overall Height: 28"

Overall Width: 14"

Overall Depth: 16"

Weight: 35 lbs.

220 VAC



9N56

MEDICAL EQUIPMENT CLASSIFIED BY
UNDERWRITERS LABORATORIES INC.
WITH RESPECT TO ELECTRIC SHOCK,
FIRE, MECHANICAL AND OTHER HAZARDS
ONLY IN ACCORDANCE WITH UL 2601-1,
AND CAN/CSA C22.2 NO.601.1

EXPLODED VIEW FOR 120 VAC 60 HZ. UNIT ONLY

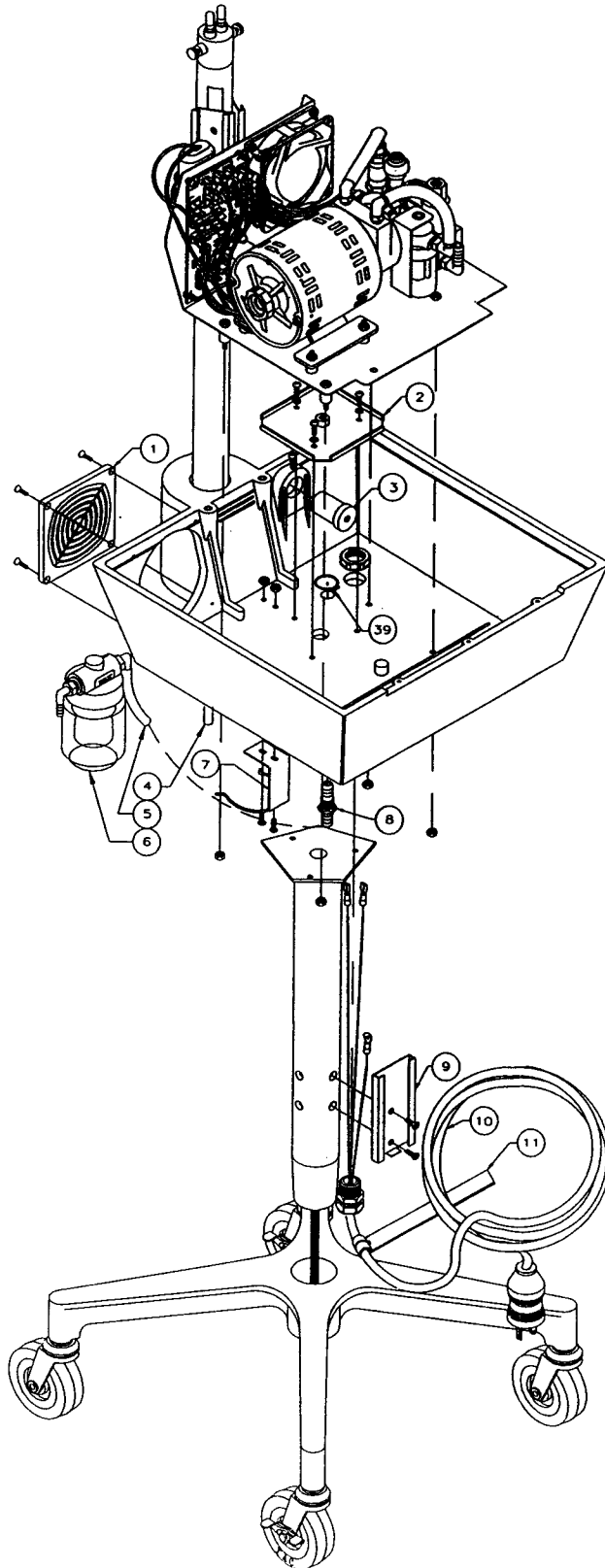

FIGURE - 1

EXPLODED VIEW FOR 120 VAC 60 HZ. UNIT ONLY

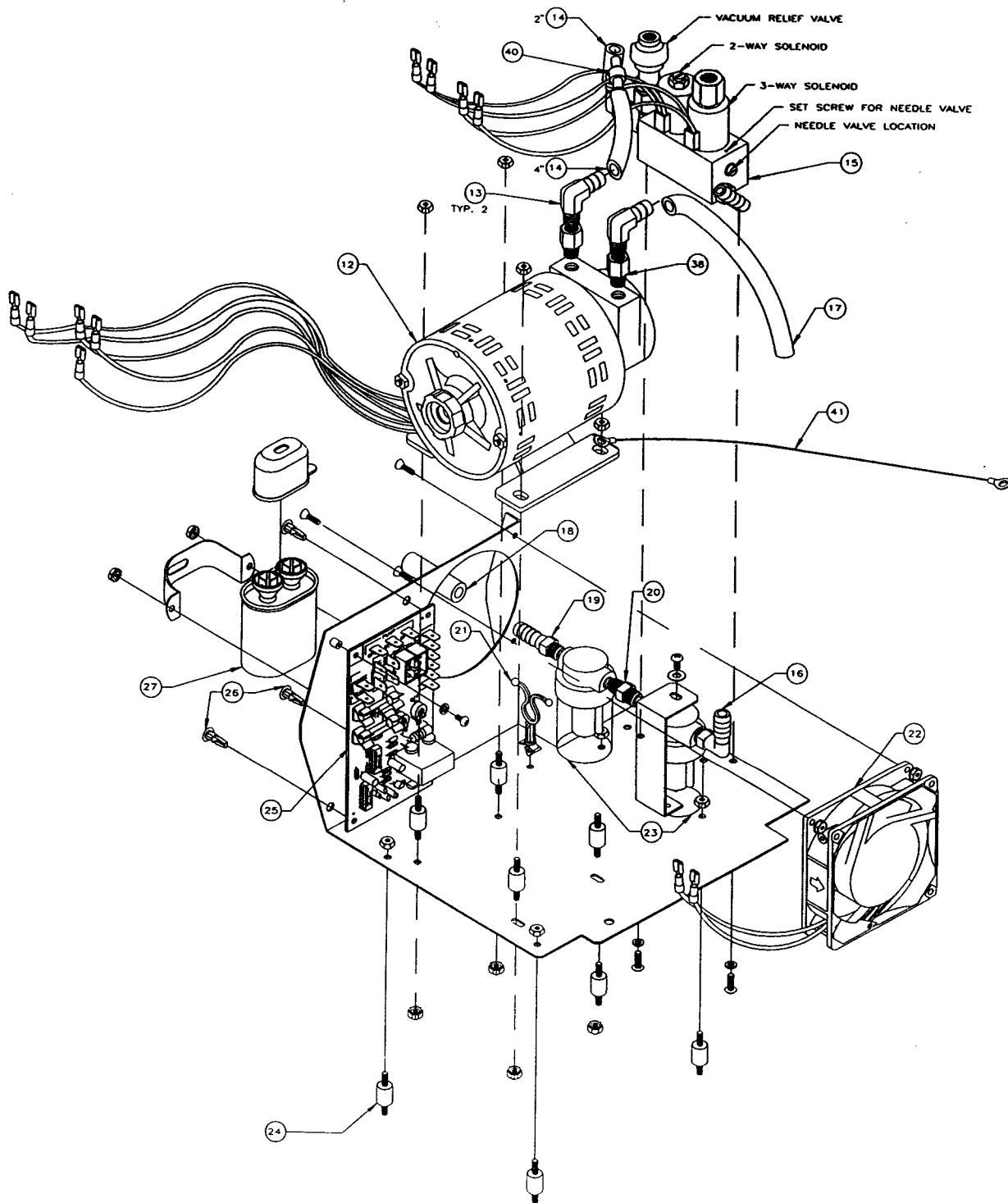

FIGURE-2

EXPLODED VIEW FOR 120. VAC 60 HZ. UNIT ONLY

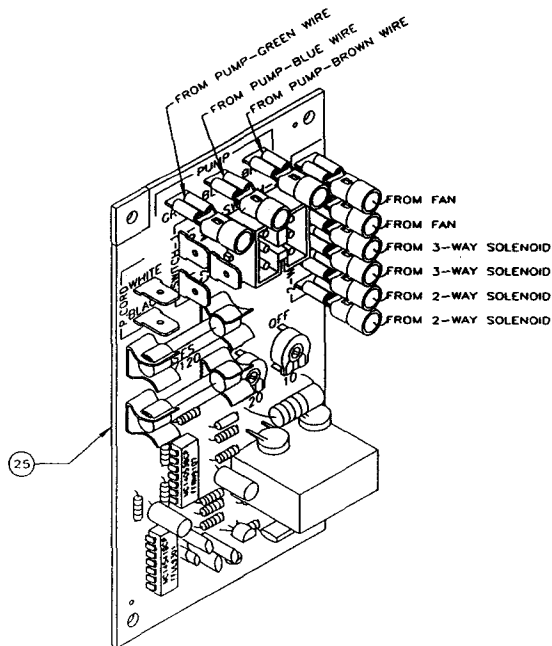
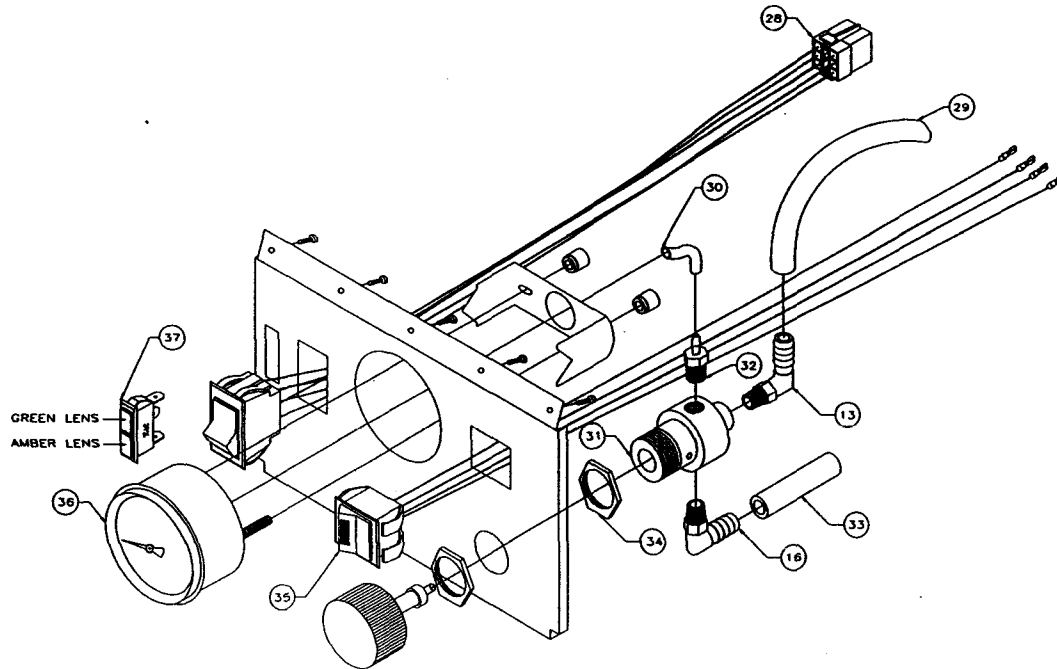

FIGURE - 3

**MOBLVAC 120 VAC PARTS LIST
REFERENCE FIGURES 1,2,3 ONLY**

ITEM	QTY	PART NO.	DESCRIPTION
1	1	756303	FILTER ASSEMBLY, INLET
2	1	756309	BRACKET, BASE SUPPORT
3	1	5581	MOUNT, DISPOSABLE FILTER
4	36	703501	TUBING, VINYL 3/8ID X 9/16OD
5	9.5	5100162	TUBING SILICONE 5/16"ID
6	1	756400	OVERFLOW TRAP ASSEMBLY
7	1	756310	BRACKET, OVERFLOW TRAP
8	1	756318	CONNECTOR, BRASS PANEL FOR 3/8" TUBING
9	1	756307	BRACKET, COLLECTION CANISTER
10	1	756020	8' POWER CORD REPLACEMENT KIT, MOBLVAC III
11	1	754004	STRAP, ONE WRAP VELCRO
12	1	5511	KIT, PUMP REPLACEMENT
13	2	5100102	FITTING, BARB 1/8NPT X 3/8 ID BRASS
14	6	5100162	TUBING, SILICONE 5/16 ID
15	1	756320	SOLENOID MANIFORLD ASSEMBLY, MOBLVAC III
16	1	703003	FITTING, ELBOW 3/8 BARB X 1/8 NPT WHITE
17	3.5	5100162	TUBING, SILICONE 5/16 ID
18	3.5	5100162	TUBING, SILICONE 5/16 ID
19	1	703010	FITTING, 1/8 NPT X 5/16" BARB
20	1	5657	HEX NIPPLE BRIGHT NICKEL PLATED
21	1	756354	MOUNT, STANDOFF WIRE W/LOCK
22	1	756260	KIT, FAN, MOBLVAC III
23	2	5526-01	MUFFLER EXHAUST BOTTLE
24	8	756353	BUMPER, VIBRATION 3/8"L STUDS
25	1	756355	TIMER, CIRCUIT BOARD MOBLVAC III C/I 120V
26	3	5100073	SPACER, PC BOARD
27	1	756370	CAPACITOR KIT
28	1	756205	SWITCH ASY, C/I
29	9.5	5100162	TUBING, SILICONE 5/16 ID
30	5	8023	TUBING, SILICONE 1/8 ID
31	1	756530	KIT, REGULATOR ASSEMBLY MBV III
32	1	5591	CONN 1/8 NPT X 1/8 BARB
33	15	5100162	TUBING, SILICONE 5/16 ID
34	2	3609	LOCKING NUT, REGULATOR
35	1	756204	SWITCH, POWER
36	1	756250	VACUUM GAUGE KIT 0-300 MMHG
37	1	756214	LIGHT, NEON INDICATOR
38	2	5543-A	EXTENSION 1/8 MPT X 1/8 FPT
39	1	756321	RING, RETAINING 1/2" SHAFT
40	1	756359	VALVE CHECK
41	1	756358	CABLE, SHROUD RESTRAINT

REPLACEMENT KITS	PARTS INCLUDED
756250	GAUGE
VACUUM GAUGE KIT 0-300 MMHG	MOUNTING BRACKET
	MOUNTING NUTS
	REGULATOR
756530 REGULATOR KIT	FITTING, ELBOW 3/8 BARB X 1/8 NPT WHITE
	FITTING, ELBOW 3/8 BARB X 1/8 NPT BLACK
	CONN 1/8 NPT X 1/8 BARB
	MOUNTING NUTS
	MOUNTING STRAP D
756370 CAPACITOR KIT	CAPACITOR 5 MFD
	CAPACITOR TERMINAL COVER BOOT
	MOUNTING STRAP D
5511 VACUUM PUMP REPLACEMENT KIT	VACUUM PUMP
	FITTING, BARB 1/8NPT X 3/8 ID
	EXTENSION 1/8 MPT X 1/8 FPT
5801ASY P.M. MOBLVAC	FILTERS
	TUBING

EXPLODED VIEW FOR 220 VAC 50 HZ. UNIT ONLY

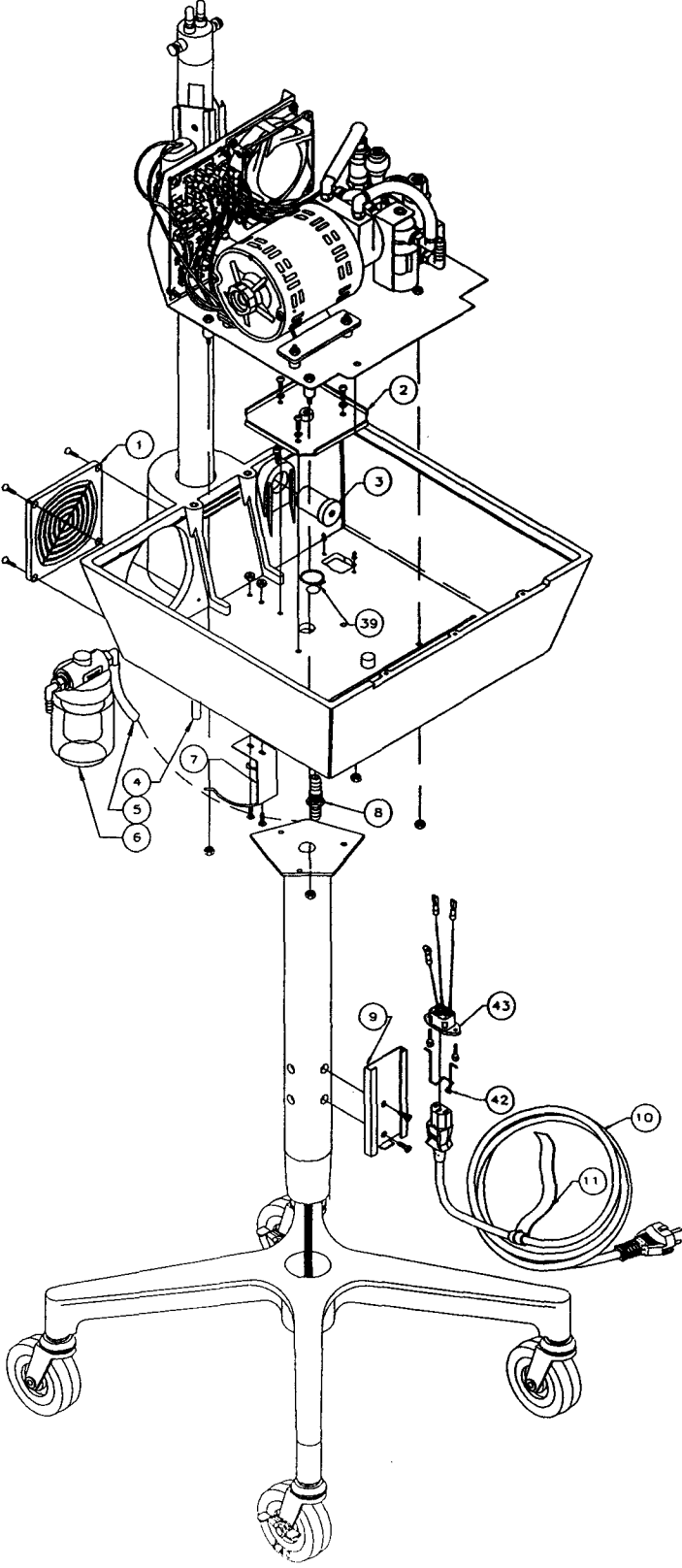

FIGURE - 4

EXPLODED VIEW FOR 220 VAC 50 HZ. UNIT ONLY

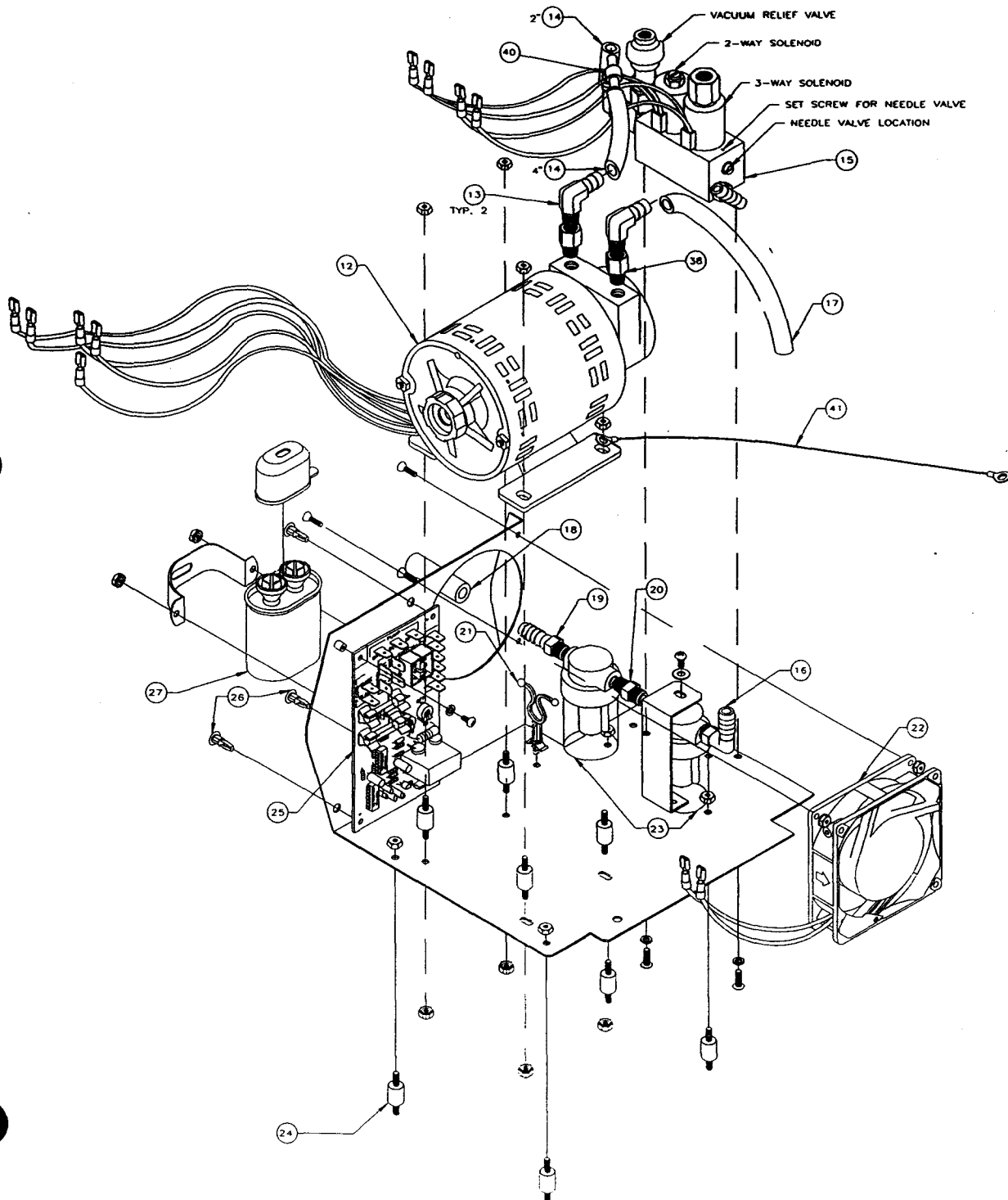

FIGURE - 5

EXPLODED VIEW FOR 220 VAC 50 HZ. UNIT ONLY

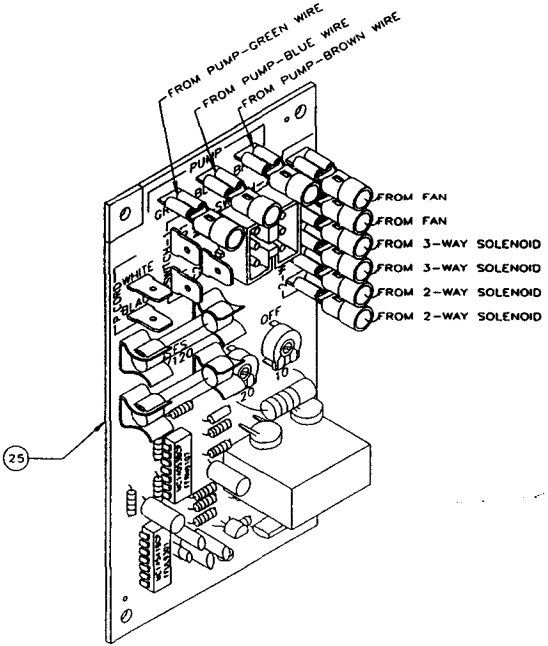
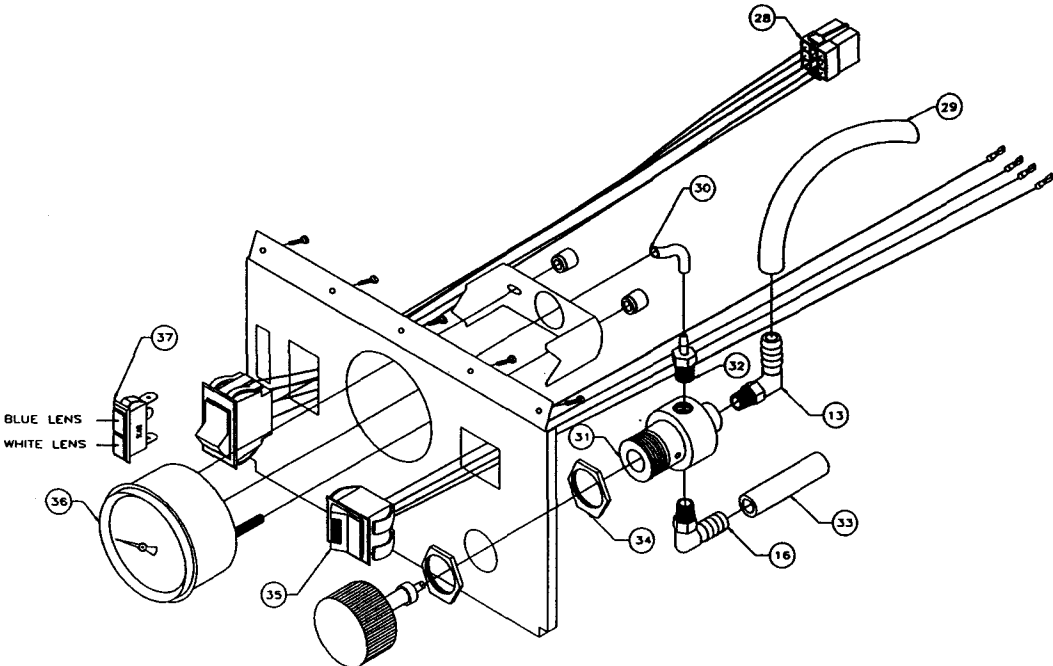

FIGURE - 6

**MOBLVAC 220 VAC PARTS LIST
REFERENCE FIGURES 4,5,6 ONLY**

ITEM	QTY	PART NO.	DESCRIPTION
1	1	756303	FILTER ASSEMBLY, INLET
2	1	756309	BRACKET, BASE SUPPORT
3	1	5581	MOUNT, DISPOSABLE FILTER
4	36	703501	TUBING, VINYL 3/8 ID X 9/16 OD
5	9.5	5100162	TUBING SILICONE 5/16" ID
6	1	756400	OVERFLOW TRAP ASSEMBLY
7	1	756310	BRACKET, OVERFLOW TRAP
8	1	756318	CONNECTOR, BRASS PANEL FOR 3/8" TUBING
9	1	756307	BRACKET, COLLECTION CANISTER
10	1	766401	POWER CORD, 220 VAC DETACHABLE
11	1	754004	STRAP, ONE WRAP VELCRO
12	1	766414	KIT, PUMP REPLACEMENT 220 VAC
13	2	5100102	FITTING, BARB 1/8NPT X 3/8 ID BRASS
14	6	5100162	TUBING, SILICONE 5/16 ID
15	1	766320	SOLENOID MANIFORLD ASSY, MOBLVAC III 220 VAC
16	1	703003	FITTING, ELBOW 3/8 BARB X 1/8 NPT WHITE
17	3.5	5100162	TUBING, SILICONE 5/16 ID
18	3.5	5100162	TUBING, SILICONE 5/16 ID
19	1	703010	FITTING, 1/8 NPT X 5/16" BARB
20	1	5657	HEX NIPPLE BRIGHT NICKEL PLATED
21	1	756354	MOUNT, STANDOFF WIRE W/LOCK
22	1	766415	KIT, FAN 220 VAC
23	2	5526-01	MUFFLER EXHAUST BOTTLE
24	8	756353	BUMPER, VIBRATION 3/8" L STUDS
25	1	766304	TIMER, CIRCUIT BOARD MOBLVAC III C/I 220 VAC
26	3	5100073	SPACER, PC BOARD
27	1	766416	KIT, CAPACITOR 3 MFD
28	1	756205	SWITCH ASY, C/I
29	9.5	5100162	TUBING, SILICONE 5/16 ID
30	5	8023	TUBING, SILICONE 1/8 ID
31	1	756530	KIT, REGULATOR ASSEMBLY MBV III
32	1	5591	CONN 1/8 NPT X 1/8 BARB
33	15	5100162	TUBING, SILICONE 5/16 ID
34	2	3609	LOCKING NUT, REGULATOR
35	1	766214	SWITCH, POWER 220 VAC
36	1	756250	VACUUM GAUGE KIT 0-300 MMHG
37	1	766207	LIGHT, NEON INDICATOR 220 VAC BLUE/WHITE
38	2	5543-A	EXTENSION 1/8 MPT X 1/8 FPT
39	1	756321	RING, RETAINING 1/2" SHAFT
40	1	756359	VALVE CHECK
41	1	756358	CABLE, SHROUD RESTRAINT
42	1	766412	KIT, RETAINER CLIP
43	1	766413	KIT CONNECTOR, BUSINESS MACHINE

REPLACEMENT KITS	PARTS INCLUDED
756250	GAUGE
VACUUM GAUGE KIT 0-300 MMHG	MOUNTING BRACKET
	MOUNTING NUTS
756530	REGULATOR
REGULATOR KIT	FITTING, ELBOW 3/8 BARB X 1/8 NPT WHITE
	FITTING, ELBOW 3/8 BARB X 1/8 NPT BLACK
	CONN 1/8 NPT X 1/8 BARB
	MOUNTING NUTS
766415	CAPACITOR 3 MFD
CAPACITOR KIT	CAPACITOR TERMINAL COVER BOOT
	MOUNTING STRAP D
766414	VACUUM PUMP
VACUUM PUMP REPLACEMENT KIT	FITTING, BARB 1/8NPT X 3/8 ID
	EXTENSION 1/8 MPT X 1/8 FPT
5801ASY	FILTERS
P.M. MOBLVAC	TUBING