

CLEMENTS

proven through performance

HiVac
**High Vacuum High Flow
Suction Pump**
SUC 84109

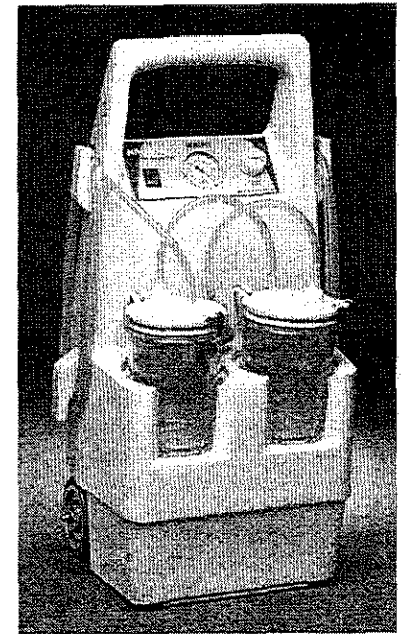

User Manual

Manual No. SUC 91005 414
Issue 17

Safety

Thank you for purchasing this Clements HiVac High Suction Pump.

For your safety it is imperative that this unit only be operated by authorised personnel in accordance with the instructions as described in this manual. Operated in this way, the HiVac High Suction Pump will provide the standard of service specified.

Due to continual improvements in product design, the HiVac High Suction Pump may vary in detail from the descriptions in this manual. In the event of further questions please contact your local distributor or BMDi TUTA Healthcare direct.

User Manual
HiVac High Suction Pump
Manual Number SUC 91005 414 Issue 17

Copyright © 2010 BMDi TUTA Healthcare Pty Ltd

The information in this manual was originated by, and is the exclusive property of BMDi TUTA Healthcare Pty Ltd. It is furnished for customer information only, and is not an authorisation or licence to make this product or to furnish this information to others.



BMDi TUTA Healthcare Pty Ltd
Level 17, 275 Alfred St
North Sydney NSW 2060
Australia
Phone: +61 2 9466 5300
Fax: +61 2 9922 7165

Contents

Classifications	4
Specifications	5
Transportation and Storage	6
Description	8
Installation and Operation	9
Accessories and Spares	13
Maintenance	15
Troubleshooting	17
Diagnostic Setup	19
Disassembly and Repair	21
Emissions Guidance Table 201	23
Immunity Guidance Table 202	24
Immunity Guidance Table 204	25
Warranty	26

Identification

SUC 84109 HiVac High Vacuum / High Flow Suction Pump

Intended Use

To provide a continuous vacuum source, within the stated operating vacuum range, for the aspiration of fluids and particulate matter in medical procedures carried out by clinically trained and authorized personnel.

Uninterrupted Availability

This equipment is mains powered. If patient care requires the uninterrupted availability of a source of vacuum, the clinical facility must make provision for either a backup power supply or standby suction units which are battery or manually powered.

Classifications	
GMDNS Code	36776
GMDNS Term	Suction Unit, High Vacuum / High Flow
GMDNS Synonym	Aspirator
Device Class	Class IIa
Electric Shock Protection	Class I Equipment
Additional Electric Shock Protection	Defibrillation-proof Type BF Applied Part
Sterilisation	Not supplied in sterile state
Anaesthetic Rating	NOT Category AP NOT Category APG
Operation Mode	Continuous operation

Specifications

HiVac SUC 84109

Power Rating	220/240 V 50Hz 1.6 A	230 V 60Hz 1.6 A
Vacuum Range	0 to -98 kPa 0 to -735 mm Hg	0 to -98 kPa 0 to -735 mm Hg
Max Flow Rate (free air)	32 litre / min	36 litre / min
Motor	Thermally protected PSC motor	
Pump	Oil Less twin piston	
Ambient Requirement	Continuous operation in ambient temperatures of 5°C to 35°C.	
Filters	Inlet: disposable bacteria filter Exhaust: clean, bleached cotton wool (5g) Internal: disposable hydrophobic filter	
Collection Jar	2 x 2 litre autoclavable, shatter resistant polycarbonate jars with non-static polypropylene bungs and overflow shut-off valves.	
Regulator	Needle Valve	
Gauge	Bourdon tube type Dual Scale, mm Hg / kPa. Accuracy ±3% FSD	
Gauge Range	0 to -760 mm Hg graduated at 20 mm Hg 0 to -100 kPa graduated at 5 kPa	
Unit Dimensions	Width 406mm, Depth 305mm, Height 800mm Weight 16.5kg	
Standard Conditions	25°C, Sea Level, 100kPa	
Environment	Indoor	

Transportation and Storage

Environmental conditions for transportation and storage are shown in the following table. In addition, for vehicular transportation, the unit should be packed in its original packaging and kept upright.

Parameter	Minimum	Maximum
Temperature	10°C	40°C
Humidity	60% RH	95% RH
Barometric Pressure	700 mBar	1060 mBar

Warning Symbols Legend

The warning symbols marked on the equipment and their meanings are shown as follows.



Attention, consult accompanying documents



Dangerous voltage inside



Defibrillation-Proof Type BF applied part

Electromagnetic Interference

This equipment generates, uses and can radiate radio frequency energy and, if not installed and used in accordance with the instructions, may cause harmful interference to radio communications. However, there is no guarantee that interference will not occur in a particular installation. If this equipment does cause harmful interference to radio or television reception, which can be determined by turning the equipment off and on, the user is encouraged to try to correct the interference by one or more of the following measures:

- Reorient or relocate the receiving antenna.
- Increase the separation between the equipment and the receiver.
- Connect the equipment into an outlet on a circuit different from that to which the receiver is connected.
- Consult the dealer or an experienced radio/TV technician for his or her help.

Changes or modifications to the equipment not expressly approved by Clements could void the user's authority to operate the equipment.

Description

The Clements HiVac High Suction Pump is a mobile, enclosed suction pump designed for high suction and high flow.

The main feature of this unit is the low maintenance piston motor and pump assembly which can generate suction strengths from 0 to -735 mm Hg (-98 kPa) with flow rates up to 32 litres of Free Air Per Minute (FAPM), depending on the model and power supply.

The unit is mounted on large rubber wheels which make it easy to move to any part of a hospital. The unit also has a storage compartment at the rear to house additional tubing, handpieces and other items needed when using the pump.

Main Components of Unit

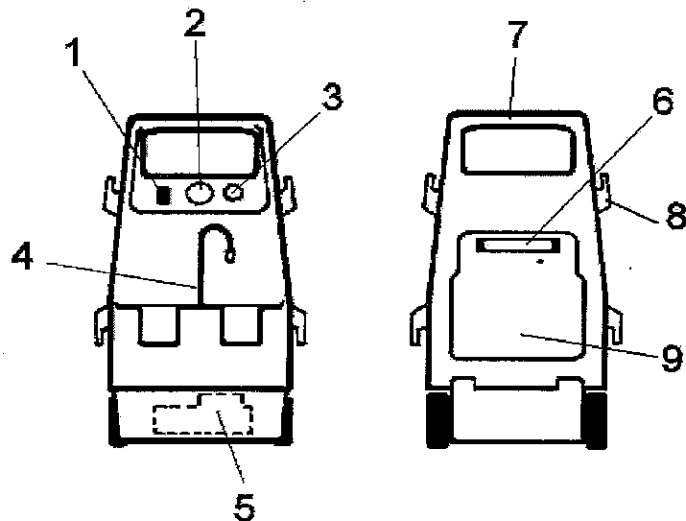

1	Power Switch	6	Exhaust Filter
2	Vacuum Gauge	7	Handle
3	Regulator Control Knob	8	Tube Storage Hooks
4	Inlet Connection	9	Storage Compartment
5	Pump (Internal)		

Installation and Operation

Installation

The Clements HiVac High Suction Pump is supplied with:

- 2 x 2 litre Collection Jar with Bung Assembly
- 1 x Single Use Handpiece
- Yellow Suction Tubing

Important

Remove strapping from motor before starting. Ensure power is disconnected before opening unit.

WARNING

This unit can generate high vacuums. It must not be used for applications which require low vacuum. Always check patient requirements before applying the Clements HiVac High Suction Pump.

For applications which require low vacuum, please contact your distributor for information about the Clements Low Suction range of products.

Connecting The Collection Jars

Because the unit is fitted with two Collection Jars it can either be connected in a single-jar arrangement or a double-jar arrangement.

With the single-jar arrangement, only one jar is in use at a time, with the second jar on standby. As one jar is filled it is disconnected, so that it can be emptied, and the other jar is connected.

The double-jar arrangement allows both jars to be in use at the same time, thus providing longer periods between changeover.

Single-Jar Arrangement

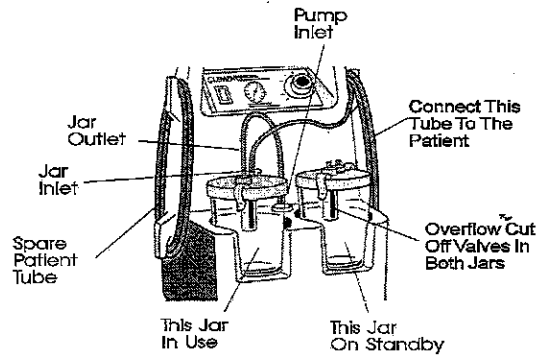

To connect the Collection Jars in a single-jar arrangement, use the following procedure and refer to the block diagram below.

1. Place two clean jars in the holders, ensuring that both jars are fitted with an Overflow Cut Off Valve.
2. Connect the SUCTION outlet of the jar to be used first to the Bacteria Filter inlet on the main unit.
3. Connect the PATIENT inlet of the jar to be used first to the Suction Tube leading to the patient.
4. When the first jar is full, disconnect it and use steps 2 and 3 to connect the second jar.

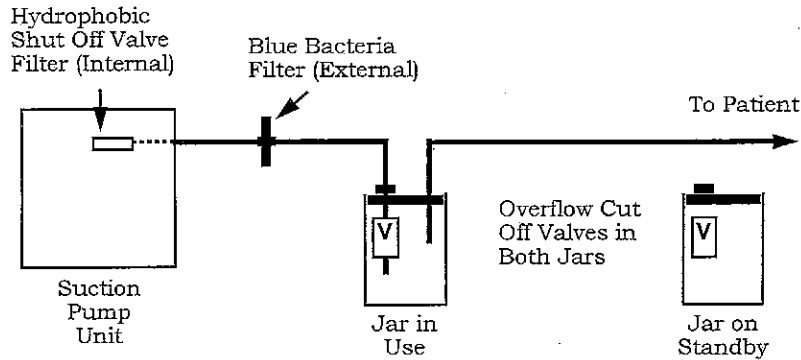

Double-Jar Arrangement

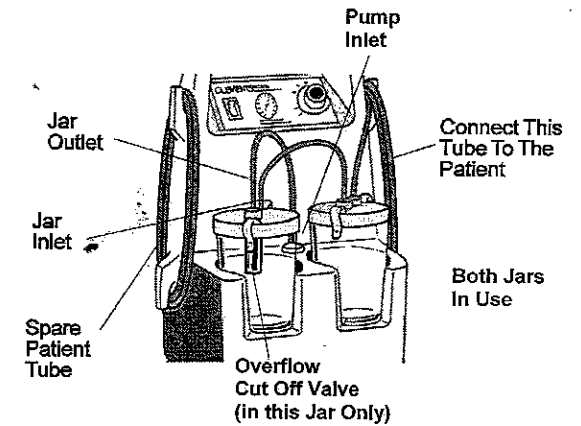

To connect the Collection Jars in a double-jar arrangement, use the following procedure and refer to the block diagram below.

1. Place two clean jars in the holders, ensuring that only one jar, Jar 1, is fitted with an Overflow Cut Off Valve.
2. Connect the SUCTION outlet (with the Overflow Cut Off Valve) of Jar 1 to the Bacteria Filter inlet on the main unit.
3. Connect the PATIENT inlet of Jar 1 to the SUCTION outlet of the jar without an Overflow Cut Off Valve, Jar 2.
4. Connect the PATIENT inlet of Jar 2 to the Suction Tube leading to the patient.

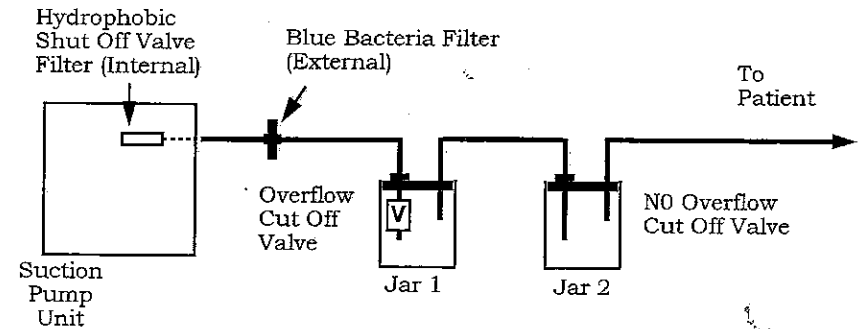

Operation

To operate the Pump, follow the steps listed below.

1. Place the pump on a level surface with a 15cm clearance from walls or other objects.
2. Install the Collection Jars and Suction Tubing in either the single-jar or double-jar arrangement as described in the Connecting The Collection Jars section on page 8.
3. Connect the unit to the mains power supply and switch the power on at the mains supply outlet.
4. Press the Power Switch down into the 'I' (ON) position and the Motor will run.
5. Occlude the Suction Tubing and adjust the Regulator, by turning the knob, to obtain the required vacuum level, as indicated on the Vacuum Gauge.
6. Check that there is no loss of vacuum in the Suction Tubing and fittings.
7. Connect the catheter to the patient.
8. Check the Collection Jars to ensure that suction is being applied correctly.

Please Note:

- Although the Collection Jars are fitted with Overflow Cut Off Valves, the fluid levels should be monitored to prevent spill-over into the pump unit. The Hydrophobic Filter fitted to the inlet of the pump acts as a single use shut-off valve to protect the pump. It must be replaced if fluid has spilled over into the pump unit.
- Always start the pump with Suction Tubing unoccluded. Always clear any blockages before re-starting the pump.
- The pump motor is protected by a thermal overload mechanism that will stop the pump if the temperature exceeds a pre-set level. The mechanism will then automatically restart the Pump after the motor has cooled to the appropriate temperature.

If the motor thermal overload trips, switch the power off at the mains switch. This will prevent unexpected re-starting of the pump when the thermal overload automatically resets upon cooling.

- If it is suspected that fluid may have entered the pump, either by an external spill or by a jar overflow, the unit must be taken out of service until the fault has been fixed and its continued electrical safety has been confirmed. The service department must also be notified of any potential biohazard.

Accessories and Spares

Accessories

SUC 80297 001	Yellow Suction Tubing (20 metre roll)
SUC 80301	2 litre Collection Jar for Suction Pumps (Jar Only)
SUC 80350	Metal Handpiece with Finger Valve and Multi Hole Tip
SUC 80404 001	Disposable Plastic Handpiece (Pack of 10)
SUC 80490	Metal Handpiece with Multi Hole Tip
SUC 84100 162	Blue Bacteria Filter (Set of 12)
SUC 84200 033	Bung Assembly with Overflow Cut Off Valve for 2 litre Collection Jar
SUC 91005 414	User Manual for the HiVac High Suction Pump

Spares

MUL 94003 702	Fuse T5.0 Amp 250V
MUL 94004000	Power Switch
SUC 37043	Cotton Wool for Suction Pumps Exhaust Filter (Pack of 10, 5 grams each)
SUC 80330	High Vacuum Gauge 0-100kPa
SUC 84100 049	Exhaust Filter Assembly for Suction Pumps
SUC 84100121	Resilient Motor Mount (Pack of 4)
SUC 84100 405	Hydrophobic Shut-Off Valve Filter (Pack of 5)
SUC 84100 505	Footswitch Kit for Suction Pumps with (Switch, Pneumatic Actuator)
SUC 84109 002	Motor and Pump for Hi Vac/Hi Flo
SUC 84200 501	Seal for Collection Jar Bung (Set of 2)
SUC 84200 502	Suction Inlet Nipple for 2 litre Jar Bung (Set of 4)
SUC 84200 503	Kit Grey Bung Float Chamber (Set of 2)
SUC 84200 518	Washer for Overflow Valve (Pack of 4)
SUC 84200 519	Blue Male Nipple for Bacteria Filter (Pack of 10)
SUC 84200 520	Blue Female Nipple for Bacteria Filter (Pack of 10)
SUC 89107	Kit for Pump Vacuum Controller (Needle Valve Type)
SUC 89240 069	Regulator Knob Replacement Kit for Suction Pumps (Regulator Knob, Screw)

Maintenance

IMPORTANT

There are no user-serviceable components inside. Maintenance must be carried out by qualified personnel only.

To keep your Clements HiVac High Suction Pump in good condition, the following maintenance is recommended.

After Each Operation

- **Blue Bacterial Filter**
The blue bacterial filter is an important device to help protect the pump from moisture and bacteria taken from patient airways. Clements recommend that the filter be changed every month or when the unit is used on infectious patients or when damp or discoloured.
- **Housing**
Wipe clean with a damp soapy cloth. Do not immerse or allow liquid to enter the housing.
- **Suction Tubing**
Suction Tubing should be sterilised with sterilants determined by local protocols and compatible with PVC tubing. Suction Tubing may be autoclaved to a maximum of 121°C for 20 minutes. At higher temperatures the Suction Tubing will discolour and lose shape.
- **Collection Jars**
Place jars upright or up-side-down in autoclave: **not on their sides**. Autoclave to a maximum of 136°C for 10 minutes. Do not use phenolic solutions as disinfecting agents in polycarbonate jars.
- **Bung**
Disconnect float cage and float from Bung. Place all items upright or up-side-down in autoclave: **not on their sides**. Autoclave all items to a maximum of 136°C for 10 minutes.

Note: Do not use abrasive cleaning agents as this may damage plastic surfaces and reduce the expected performance of an item.

After Every 100 Hours or 2 Months of Operation

- Replace the Exhaust Filter:
 1. Remove the Exhaust Filter from the rear of the unit.
 2. Unscrew the caps and replace the cotton wool. The filter takes 5 gram of bleached and teased-out cotton wool.
- Check all Suction Tubing and replace if it is perished, soft or discoloured. Also check the tubing nipples.
- Check the seal rings on the Bungs and replace them if they are hard, cracked or perished. Check the fit of the Bung in the Collection Jar.
- Check the Overflow Cut Off Valve seals and replace them if they are perished or damaged.

IMPORTANT

The preceding maintenance should also be carried out immediately after use with infectious patients.

Disposal and Recycling

Waste Materials

The contents of the collection jars, suction tubing, bacteria filter, internal hydrophobic shut-off filter, or the cotton wool in the exhaust filter may contain biohazard wastes. Handle using safe handling procedures, which may include the use of rubber gloves and eye protection, and dispose of according to local protocols for biohazard materials.

Recycling

At the end of their service life, the pump and accessories should be dismantled if necessary, and returned to a local materials recycling centre.

Troubleshooting

Fault	Check	Rectify
No Suction But Motor is Working	Tubing Blocked	Clear or Replace
	Overflow Cut Off Valve Closed	Clear, Replace or Empty Jar
	Hydrophobic Shut - Off Valve Filter Blocked	Replace Hydrophobic Shut-Off Valve Filter
	Inlet Blocked	Clear
	Vacuum Gauge Defective	Replace Vacuum Gauge
	Regulator Blocked	Clear or Replace
	Bung Not Sealing	Adjust or Fit New Seal
	Regulator at Zero	Adjust Setting
No Suction: Motor Not Working	Mains Fuse Blown	Replace
	Faulty Mains Power Lead	Replace
	Power Not Turned On	Turn On
	Unit Fuses Blown	Replace
	Thermal Overload Activated	Wait For Unit To Cool Down
No Suction But Humming Can Be Heard From Motor	Blockage In Pump	Dismantle And Clean Pump
	Motor Windings	Replace Motor

Fault	Check	Rectify
Not Enough Suction	Regulator Setting Too Low	Adjust To Correct Setting
	Leaks In Tubing or Fittings	Tighten Connections
	Blockage In Tubing or Fittings	Clear or Replace
	Hydrophobic Shut-Off Valve Filter Blocked	Replace Hydrophobic Shut-Off Valve Filter
Excessive Noise	Pump Worn	Replace Pump
Coming From Pump	Pump Incorrectly Assembled	Assemble Correctly
Pump Runs Intermittently	Thermal Overload Is Cutting In and Out	Disconnect Mains Power And Wait For Unit To Cool Down

Replacing the Hydrophobic Shut Off Valve Filter

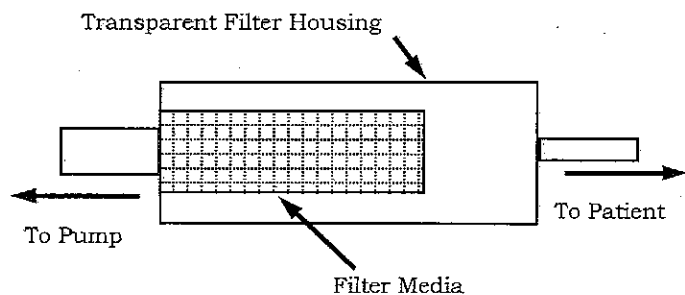

To ensure there is no entry of fluid into the pump the Hydrophobic Shut Off Valve Filter MUST be fitted as shown above.

Setup for Diagnostic and Performance Testing

Note that the following arrangements are not used for actual suctioning applications. They are specified to remove unnecessary variations when diagnosing faults and as a standard setup for performance measurement.

Vacuum Check

1. Unoccluded - zero check

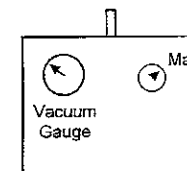

Disconnect all items from inlet and with pump switched off, confirm that gauge reads zero. A non-zero reading indicates a faulty gauge. Set vacuum control knob to maximum, switch on pump and confirm that gauge reads zero. A non-zero reading indicates obstruction in internal tubing or connections.

2. Occluded - vacuum check

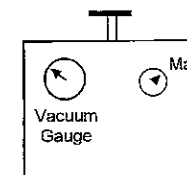

Switch on pump and occlude inlet. Note maximum vacuum reading.

3. Occluded - gauge check

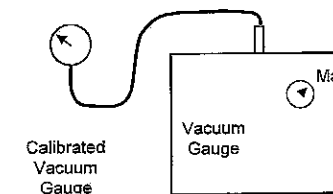

Connect a calibrated vacuum gauge directly to inlet and repeat maximum vacuum reading. Confirm that pump gauge reads within the specified tolerance.

Flow Check

1. Occluded - leak check

Jar: SUC 81099 (1 litre)
 or SUC 80312 (2 litre)
 Tubing: SUC 80297 (8x13mm)

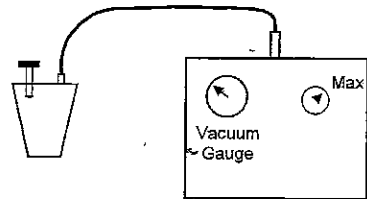

Connect pump as shown in diagram. Set vacuum control knob to maximum, and switch on pump. Occlude jar inlet and confirm that pump achieves the same maximum vacuum as in the previous vacuum check setup. Any difference indicates leaks in jar or connections.

2. Unoccluded - flow check

Jar: SUC 81099 (1 litre)
 or SUC 80312 (2 litre)
 Tubing: SUC 80297 (8x13mm)

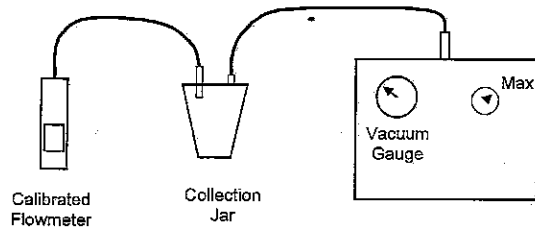

Connect pump as shown in diagram. Set vacuum control knob to maximum, and switch on pump. Connect jar inlet to calibrated flow meter and note flow reading. If flow is significantly below specification, check internal tubing and pump itself (or internal shutoff valve if fitted).

Disassembly and Repair

Dismantling The Pump

The steps for dismantling the Pump are as follows.

1. Disconnect the unit from the mains power supply.
2. Remove Collection Jars and Suction Tubing.
3. Remove the 4 screws from the base plate tabs at the rear of the unit and push the housing forward off the base plate.
4. Remove the four cylinder head screws from each head. Remove the cylinder heads.
5. Check O-ring, pistons and replace if worn, cracked or perished.
6. Clean the inside of the cylinder head. Check flapper valves and replace if worn, cracked or perished.
7. Reassemble pump.

Fuse Replacement

The Pump is fitted with two cartridge fuses located in fuse holders that are accessible from outside the unit. To replace the fuses use the following procedure.

1. Disconnect the unit from the mains power supply.
2. Locate the two fuse holders which are mounted on the rear side of the unit at the lower right-hand side.
3. Lift off the fuse holder cover.
4. Remove the old fuses and inspect them. If they are blown, replace them with new fuses.
5. Replace the fuse holder cover.
6. Connect the unit to the mains power supply, switch the power on, and ensure that the unit is operating correctly.

Electrical Wiring Diagram

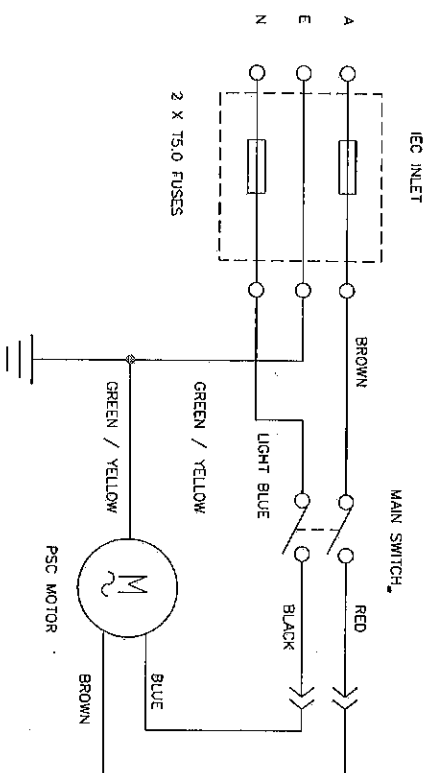

EMC Information Tables per EN60601-1-2:2001-09 Section 6.

In accordance with EN 60601-1-2:2001 Medical electrical equipment - Part 1-2: General requirements for safety - Collateral standard: Electromagnetic compatibility - Requirements and tests

- 1) "Medical Electrical Equipment needs special precautions regarding EMC and needs to be installed and put into service according to the EMC Information provided in the Accompanying Documents" (the following tables).
- 2) "Portable and Mobile RF Communications Equipment can affect Medical Electrical Equipment"
- 3) "The equipment or system should not be used adjacent to or stacked with other equipment and that if adjacent or stacked use is necessary, the equipment or system should be observed to verify normal operation in the configuration in which it is used."

The following tables provide information regarding the EMC characteristics of this Medical Electrical Equipment.

* The compliance levels of immunity referred to in tables 202 and 204 have not been arrived at by testing, but by declaration on the basis that the HiVac suction pump contains no electronic components and is inherently immune to the specified levels of electromagnetic disturbance. The performance of all functions of the HiVac suction pump are considered essential performance for the purpose of electromagnetic immunity.

Table 201 — Guidance and manufacturer's declaration - electromagnetic emissions - all equipment and systems

Guidance and manufacturer's declaration - electromagnetic emissions		
The HiVac suction pump is intended for use in the electromagnetic environment specified below. The customer or user of the HiVac suction pump should assure that it is used in such an environment.		
Emissions Test	Compliance	Electromagnetic environment - guidance
Harmonic Emissions IEC 61000-3-2	Class A	The HiVac suction pump is suitable for use in all establishments, including domestic establishments and those directly connected to the public low-voltage power supply network that supplies buildings used for domestic purposes.
Voltage Fluctuations / flicker emissions IEC 61000-3-3	Complies	
RF emissions CSIPR 14-1	Complies	The HiVac suction pump is not suitable for interconnection with other equipment.

Table 202 — Guidance and manufacturer's declaration - electromagnetic immunity
- for all equipment and systems

Guidance and manufacturer's declaration - electromagnetic immunity			
The HiVac suction pump is intended for use in the electromagnetic environment specified below. The customer or user of the HiVac suction pump should assure that it is used in such an environment.			
Immunity Test	IEC 61000 test level	Compliance level (not tested) *	Electromagnetic environment - guidance
Electrostatic discharge (ESD) IEC 61000-3-4	±6 kV contact ±8 kV air	±6 kV contact ±8 kV air	Floors should be wood, concrete or ceramic tile. If floors are covered with synthetic material, the relative humidity should be at least 30%.
Electrical fast transient/burst IEC 61000-4-4	±2 kV for power supply lines ±1 kV for input/output lines	±2 kV for power supply lines ±1 kV for input/output lines	Mains power quality should be that of a typical commercial or hospital environment.
Surge IEC 61000-4-5	±1 kV/line(s) to line(s) ±2 kV/line(s) to earth	±1 kV/line(s) to line(s) ±2 kV/line(s) to earth	Mains power quality should be that of a typical commercial or hospital environment.
Voltage dips, short interruptions and voltage variations on power supply IEC 61000-4-11	<5% U _T (>95% dip in U _T for 0.5 cycle) 40% U _T (60% dip in U _T for 5 cycles) 70% U _T (30% dip in U _T for 25 cycles) <5% U _T (>95% dip in U _T for 5 sec)	<5% U _T (>95% dip in U _T for 0.5 cycle) 40% U _T (60% dip in U _T for 5 cycles) 70% U _T (30% dip in U _T for 25 cycles) <5% U _T (>95% dip in U _T for 5 sec)	Mains power quality should be that of a typical commercial or hospital environment. The unit shut off during the >95% dip for 5 sec disturbance. If the user of the HiVac suction pump requires continued operation during power mains interruptions, it is recommended that the HiVac suction pump be powered from an uninterruptible power supply or battery.
Power frequency magnetic field IEC 61000-4-8	3 A/m	3 A/m	Power frequency magnetic fields should be at levels characteristic of a typical location in a typical commercial or hospital environment.

Table 204 — Guidance and manufacturer's declaration - electromagnetic immunity
- for equipment and systems that are NOT life-supporting.

Guidance and manufacturer's declaration - electromagnetic immunity			
The HiVac suction pump is intended for use in the electromagnetic environment specified below. The customer or user of the HiVac suction pump should assure that it is used in such an environment.			
Immunity Test	IEC 61000 test level	Compliance level (not tested) *	Electromagnetic environment - guidance
Conducted RF IEC 61000-4-6	3 Vrms 150 KHz to 80 MHz	3 Vrms	Recommended separation distance $d = [3.5/E_{1P}]^2$
Radiated RF IEC 61000-4-3	3 V/m 80MHz to 2.5 GHz	3 V/m	$d = [3.5/E_{1P}]^2$ 80 MHz to 800MHz $d = [7/E_{1P}]^2$ 800 MHz to 2.5GHz where P is the maximum output power rating of the transmitter in watts (W) according to the transmitter manufacturer and d is the recommended separation distance in metre (m). Field strengths from fixed RF transmitters, as determined by an electromagnetic site survey, should be less than the compliance level in each frequency range. Interference may occur in the vicinity of equipment marked with the following symbol



Warranty

BMDi TUTA Healthcare Medical Equipment Pty Limited ("BMDi TUTA Healthcare") warrants that this product is free from defects in workmanship and materials for a period of 12 months (3 months for batteries) from the date of shipment by BMDi TUTA Healthcare or its authorised agent to the purchaser. Subject to the conditions of this warranty, if the product fails to operate for any reason within the warranty period and the product is returned to the place of purchase at the purchaser's expense, BMDi TUTA Healthcare will repair or replace the product free of charge.

If a valid warranty claim is made within 30 days from the date of shipment, then BMDi TUTA Healthcare will also reimburse the purchaser for reasonable freight costs in returning the product to the place of purchase.

Conditions of Warranty

1. The product must be returned to the place of purchase with proof of purchase.
2. This warranty is only available to the original purchaser of the product.
3. The product must not have had its serial number removed, defaced or changed, its casing opened, its power supply altered or have been tampered with in any other way.
4. This warranty does not cover :
 - inadequate or incorrect site preparation;
 - improper installation;
 - connection to the wrong voltage;
 - failure of the product due to misuse;
 - the use or operation of the product outside of the physical, electrical or environmental specifications of the product;
 - use in a manner or environment in which the product is not designed to be used;
 - improper adjustment, calibration or operation by the purchaser;
 - the use of accessories including consumables, hardware or software which were not manufactured or approved in writing by BMDi TUTA Healthcare;

- any modifications of the product which were not authorised in writing by BMDi TUTA Healthcare;
- any contamination or leakages caused or induced by the purchaser; and
- inadequate or improper maintenance of the product.

5. This warranty does not cover normal wear and tear.
6. BMDi TUTA Healthcare will not be responsible for damage or loss caused during shipping.
7. In Australia, apart from any warranties implied by the Trade Practices Act 1974 all other warranties expressed or implied and whether arising by virtue of statute or otherwise are hereby excluded.
8. Outside Australia, all other warranties expressed or implied and whether arising by virtue of statute or otherwise (including any warranties implied by the Vienna Convention) are hereby excluded.
9. BMDi TUTA Healthcare' obligations under this warranty are limited to the repair or replacement of the product, within the terms of this warranty and the total liability of BMDi TUTA Healthcare for loss or damage of every kind whether arising pursuant to the terms of the sale of the product or otherwise in connection with the product is limited to the amount paid by the purchaser to BMDi TUTA Healthcare for the product.
10. Apart from any liability imposed by Part VA of the Trade Practices Act, BMDi TUTA Healthcare accepts no other liability for any loss or damage occasioned (including consequential loss or damages) in any way as a result of the use of the product.
11. The warranty does not extend to cover damage to the following parts as they are inherently prone to wear :
 - motor brushes
12. This warranty does not extend to cover corrosion due to any cause nor to any damage to painted or anodised surfaces.
13. BMDi TUTA Healthcare will give the purchaser the benefit of any manufacturer's warranty in respect of any components in the product which were not manufactured by BMDi TUTA Healthcare, if such a manufacturer's warranty is available.