

TEMP 3™ FLUID WARMER

OPERATORS MANUAL

7000 Series



Medical Solutions, Inc.
3901 Centerview Drive, Suite L
Chantilly, VA 20151
800-435-7600
703-834-0039 (Fax)
www.warmiv.com

TEMP 3™ FLUID WARMER

Read and understand the Operators Manual before using the TEMP 3™ Fluid Warmer.

Intended Use

The TEMP 3™ Fluid Warmer is designed to store, rapidly warm, and maintain the temperature of I.V. and irrigation fluid bags prior to their use.

The TEMP 3™ is designed to supply warmed I.V. and irrigation fluid bags for a single room, (i.e., Operating, LDR, Patient's, etc.). It is not intended to supply warmed I.V. bags or irrigation solution bags to more than one room at a time.

It is suggested that each facility should contact the fluid manufacturer to obtain the manufacturer's specifications for time and temperature for the fluids being warmed.

Unit Description

The TEMP 3™ holds up to (6) 1000ml or (6) 500 ml bags and can be attached to the wall, a K740 stand, or an anesthesia cart. A temperature controller is used to regulate the heating of the fluid bags and the over-temperature safety. The top display number (**in red**) will indicate the temperature of the bag currently being warmed while the bottom display number (**in green**) displays the desired set-point temperature. During the time that the controller is directing the unit to warm, a light will illuminate in the upper left corner of the display.

The Documentor® is designed to assist in the compliance with JCAHO® standard MM 2.20 and the I.V. bag manufacturer's specifications for time and temperature.

Important Labels and Warnings:

Model/Serial Number label

Caution: Replace fuses as marked.

Caution: Electric shock hazard, do not remove protective panel. Refer servicing to Qualified Personnel.

Caution: Verify temperature of warmed items before use.

Danger: Risk of explosion if used in the presence of flammable anesthetics.

Warning: Unit not intended for blood or blood products.

Caution: Minimum number of bags required for proper operation:

500ml - 3

1000ml - 2

Caution: Use approved cord only.

Specifications

Classification	Class 2
Dimensions	21.335" tall x 17.163" wide x 6.239" deep
Capacity	882 cubic inches
Mounting:	Bracket for Wall Provided MSI – K740 Stand
Construction	Powder Coat Finish Aluminum

Temperature Control Specifications

Temperature Setting Range	Ambient to 43°C
Factory Preset Temperature	40°C

Ambient Operating Conditions

Storage Temperature	-40 to +80°C (-40 to 176°F)
Humidity Conditions	0 to 90% up to 40°C non-condensing
Operating Temperature	-10 to +55°C (+14 to 131°F)
Atmospheric Pressure during Transporting	minimum of 16.288 in. Hg

Electrical Requirements

Power requirements	110 / 120 VAC, 60 HZ
Fused	2 each 2 amp
Amperage consumed	1.25 amps
Heater wattage	100 watts
Thermal cutout temperature	1°C over set-point temperature

Set-up Instructions

1. Remove the TEMP 3™ from the box; leave the black foam inserts inside the cabinet. The cabinet is setup with the foam inserts for Baxter 1000ml fluid bags.
2. Locate The Documentor® and remove from the shipping box. Attach The Documentor® to the TEMP 3™ following the instructions below.

Place the TEMP 3™ on its back and remove the two indicated screws.

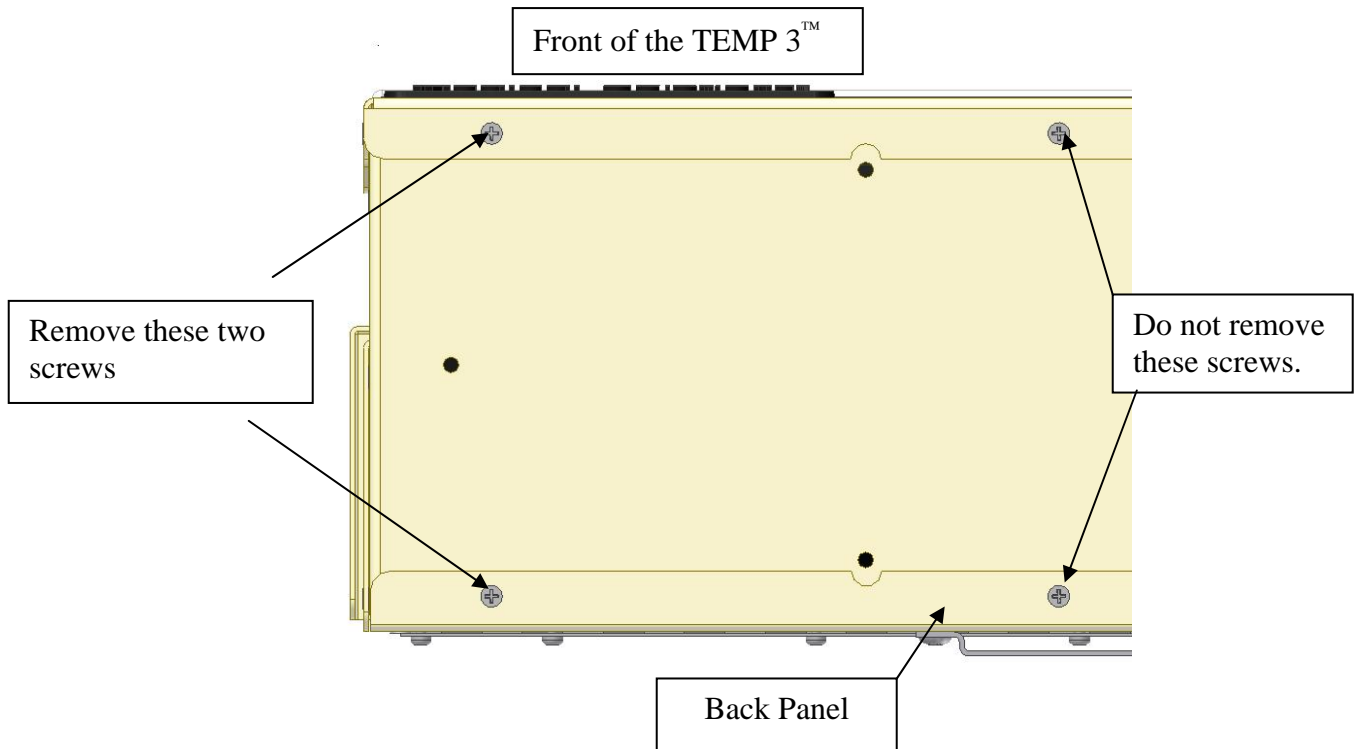

Align the holes in the TEMP 3™ Time/Clock Mounting Bracket to the empty screw holes. Secure the mounting bracket using the screws removed in step one.

Remove the 3 screws in the back of The Documentor®. Attach The Documentor® to Time/Clock Mounting Bracket using these 3 screws.

3. Locate the wall mounting bracket.
4. Mount the bracket securely in a convenient place – on a wall or cart. The TEMP 3™ loaded with 6 bags of solution will weigh approximately 30 pounds. When mounting to a wall, care should be taken to secure the bracket using suitable bolts for the wall material to support a minimum of 90 lbs.
5. Move the TEMP 3™ to the desired location, check that the power switch is “off” and plug the power cord into an approved outlet. Turn the unit on.
6. Using the key switch on the front of the cabinet unlock the doors. Load the labeled bags of solution into the cabinet through the top door and close the door. The door locks will automatically lock in approximately 15 seconds. If the door locks prior to closing the door, unlock the door using the key switch and then close the door again.

The Documentor[®] Instructions

Prior to loading the cabinet with I.V. bags, use The Documentor[®] to label the I.V. bags with a future date that follows the manufacturer's recommendation for the length of time a bag is to be warmed.

“Future Date Label”

To create a future date label (See The Documentor[®] Resetting Instructions for adjusting the clock date):

- i) Hold the Label sheet face up;
- ii) Line up the arrow on The Documentor[®] under the words “Remove Fluid By:” on the label;
- iii) Push the label sheet towards the arrow until The Documentor[®] is activated; and
- iv) Place a label on each I.V. bag for documentation and compliance purposes.

Load the labeled bags of solution into the TEMP 3[™] through the top door.

Operating Instructions

1. Load the labeled bags of solution into the cabinet through the top of the cabinet.
2. Turn the unit “on” by depressing the power switch. The switch will illuminate when energized. The controller will perform a self-test and then it will display the current temperature of the bottom bag. The factory temperature setting is 40 degrees C. To change the temperature setting, follow the instructions below.
3. The controller will display 2 temperatures in its display. The top display number (in red) will indicate the current temperature of the bottom bag in the cabinet. The bottom display number (in green) will indicate the set-point temperature (40°C). During the time that the controller is directing the unit to warm a light will illuminate in the upper left corner of the display.
4. To change the temperature setting, follow the instructions below.

TO CHANGE THE SET POINT

- i) Press the index key (left most key) to view set-point one (sp1);
- ii) press the up or down arrow keys to change the set point;
- iii) press the enter key (right most key) to accept the new set point; and
- iv) press the index key

NOTES

The TEMP 3™ may be left on continually without harm to the unit. It is suggested that each facility should contact the fluid manufacturer to obtain the manufacturer's specifications for time and temperature for the fluids being warmed.

The TEMP 3™ is not intended for Blood or Blood Products.

In the event that fluid should spill inside the cabinet – unplug the unit to prevent an electrical shock hazard and refer to step #4 of the Cleaning instructions.

The Documentor® Resetting Instructions

TO CHANGE THE DATE:

1. Plug The Documentor® into an electrical outlet.
2. Press and hold blue RESET button located on the bottom of the The Documentor®.
3. While holding down the RESET button, press and hold the • right button on the front panel.
4. While holding the • right button, release the RESET button.
5. When “Prog” appears in the display, release the • right button, Prog finishes.
6. Tap the • right button again. The display will show “0000” and the 1st digit will flash.
7. Tap the ◀ left button until the number “8” appears, then Tap the • right button twice so the third “0” is flashing.
8. Tap the ◀ left button until the number “8” appears in the third position then Tap the • right button.
9. Tap the ◀ left button until the number “8” appears in the fourth position. When the display reads “8088”, Tap the • right button.
10. When the display flashes all four digits, Tap the • right button.
11. The display flashes “P1 (date) ” .
12. Tap the • right button and the small digits on the left, representing the year, will flash.
13. Tap the ◀ left button until the desired number appears and then Tap the • right button. The digits representing the month should flash.
14. Tap the ◀ left button until the desired number appears and then Tap the • right button. The digits representing the day should flash.
15. Tap the ◀ left button until the desired number appears and then Tap the • right button.
16. When the desired date is set, Tap the • right button until the display flashes “P1 (date) ” .
17. Tap the blue RESET button to return to the standard display.

TO CHANGE THE TIME:

18. Follow steps 1-11.
19. Tap the ◀ left button. When the display flashes “P2 cloc” , Tap the • right button.
20. The hour format will flash (12 or 24). If necessary, tap the ◀ left button until 24 flashes. Tap the • right button.
21. The hour digits will flash. Tap the ◀ left button until the desired setting is achieved. (the hour must be set in military time 3:05 pm = 15:05) Tap the • right button
22. The minutes digits will flash. Tap the ◀ left button until the desired setting is achieved. Tap the • right button twice.
23. The display will flash “P2 Cloc”, Press and release the blue RESET button.

Cleaning Instructions

1. Turn the unit off and disconnect it from the power source.
2. Wipe down the cabinet with a damp cloth using a general hospital cleaner (Isopropyl Alcohol) as needed, following the manufacturer's instructions for the cleaner.
3. Avoid contact with the electrical connections and the electrical components.
4. In the event that excessive fluid enters the cabinet, disconnect power to the unit and refer to qualified service personnel. Have a qualified person remove all liquid and dry the components. Perform any necessary hospital electrical safety checks before returning the unit to service.

Trouble Shooting

1. If the unit fails to warm, do the following:
 - a. Check to see that the unit is plugged in and the power switch is on.
 - b. Check the set-point temperature setting so that the controller is directing the unit to warm.
 - c. Check to see that the minimum number of I.V. bags is loaded in the cabinet.
2. If the unit overheats call Medical Solutions, Inc.
3. Contact Medical Solutions, Inc., for any additional technical assistance @ 800-435-7600.

Preventive Maintenance Plan

The TEMP 3™ temperature controller should be verified at least once every five years. Use of the following items to accurately measure the bag temperature for verification.

Fluke 51II Digital Thermometer

6" Long .093" Diameter Type T Needle Thermocouple

(with the Thermocouple calibrated to the Thermometer)

With the outer wrap still on a 1000ml solution bag, pierce the bag through the needle injection port on the bag with an 18ga needle to make it easier to insert the Thermocouple. Insert the Thermocouple through the pierced needle injection port. Place the bag into the TEMP 3™ through the lower door of the cabinet. Feed the Thermocouple wire out of the cabinet to the Fluke Thermometer and position the probe in the center of the bag. Close the lower door. Add five additional bags to the cabinet from the top loading door.

Turn the power to the TEMP 3™ on. Adjust the temperature controller set-point temperature to 40°C. Allow the unit to operate for a minimum of 1 hour before verifying the temperatures. After the allotted time, compare the temperature on the controller to the temperature reading on the Fluke Thermometer. The two temperatures should be within one degree Celsius of each other. If the two temperature readings are within one degree Celsius of each other the temperature controller has been verified. If they are not, please contact Medical Solutions, Inc. at 800-435-7600.

If a Fluke Digital Thermometer is not available a glass laboratory thermometer may be used as an alternative. Load the unit with (6) 1000ml bags and turn the power on. Adjust the temperature controller set-point temperature to 40°C. Allow the unit to operate for a minimum of 1 hour before verifying the temperatures. Remove the bottom bag and place the end of the glass thermometer on top of and in the middle of the bag. Fold the bag over the thermometer and hold for approximately two minutes or until the thermometer stops moving. If the reading on the thermometer is between 38°C and 41°C the temperature controller has been verified. If it is not, please contact Medical Solutions, Inc., at 800-435-7600.

Service panel location and removal

Remove 5 screws,
1 on the back
and 4 on the side.

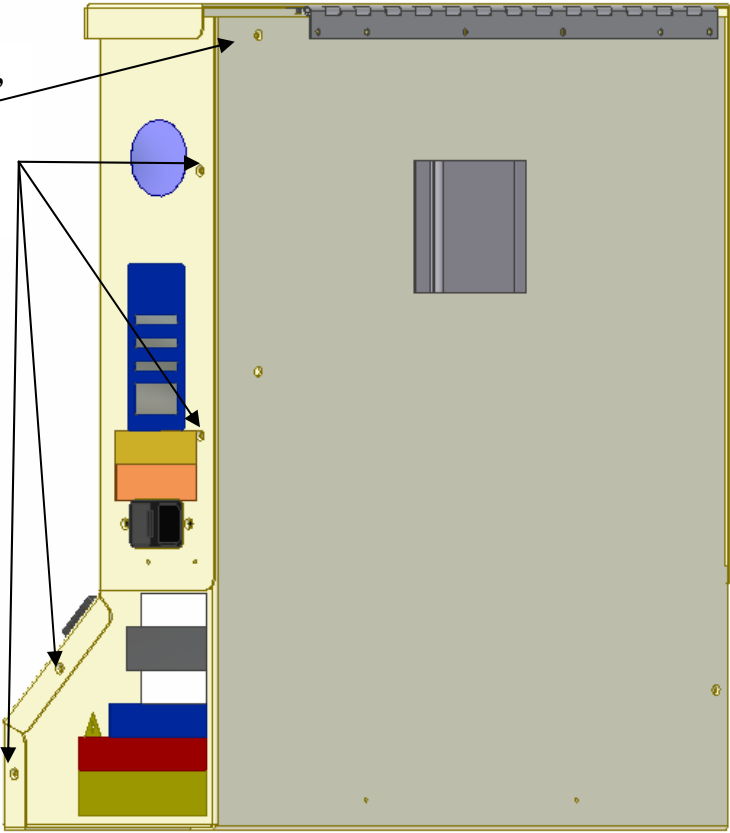

Remove the rear and
partial side panel to
access the electrical
compartment.

Remove 3 screws,
2 on the side and
1 on the back.

Remove 3 screws on the bottom

Fuse removal instructions:

To replace the fuses, disconnect the power cord from the unit. Use a flat screwdriver to unlock the fuse holder from the Power Inlet. Replace the fuses as marked.

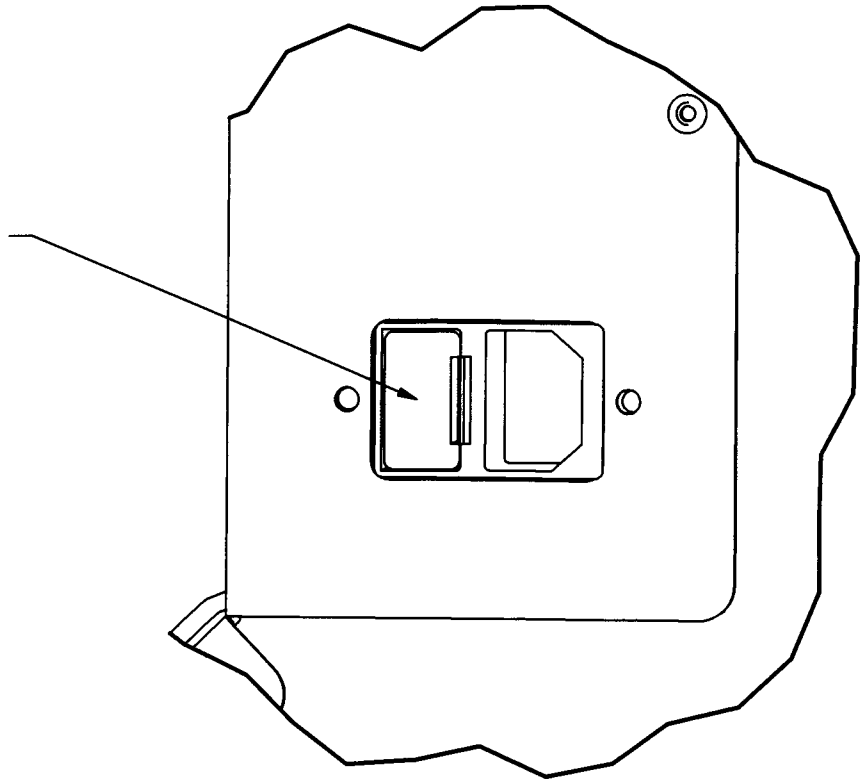

LIMITED WARRANTY

For one year from the date of shipment to the Buyer (the “Warranty Period”), MSI warrants that the Equipment provided to the Buyer shall be free from defects in workmanship and material. In the event of a breach of this warranty during the Warranty Period, MSI shall, at its option, repair or replace the Equipment, and Buyer’s remedies are limited to such repair or replacement. MSI DISCLAIMS ALL OTHER WARRANTIES, EXPRESSED OR IMPLIED, INCLUDING THE WARRANTIES OF MERCHANTABILITY OR FITNESS FOR A PARTICULAR PURPOSE. IN NO EVENT SHALL MSI BE LIABLE FOR DIRECT, INDIRECT, PUNITIVE, ECONOMIC, CONSEQUENTIAL OR OTHER DAMAGES, INCLUDING BUT NOT LIMITED TO LOST PROFITS.

To enable MSI to administer the Warranty properly, Buyer shall (1) register the Warranty using the form provided below, and (2) promptly notify MSI of any claim hereunder. As a condition to the Warranty, Buyer shall use and maintain the Equipment according to the provisions of the Operator’s service manual.

IMPORTANT: THIS IS YOUR TEMP 3™ WARRANTY REGISTRATION

Please register your warranty by filling out this page and send it to Medical Solutions, Inc., within 30 days of purchase.

- A. Hospital Name: _____
- B. Mailing Address: _____
- C. City: _____ State: _____ Zip Code: _____
- D. Contact Name: _____
- E. Date Purchased: _____
- F. Serial Number: _____
- G. Department Purchased For: _____

COPY THIS PAGE AND MAIL TO:

Medical Solutions, Inc.
3901 Centerview Drive, Suite L
Chantilly, Virginia 20151
Fax number 703-834-0039