

# OPERATION MANUAL



LAB-LINE  
 ORBIT SHAKING WATER BATHS  
 MODELS 3540 and 3540-1

POK164739

POK108685

Figure 1: OVERVIEW OF UNIT

**LAB-LINE INSTRUMENTS, Inc.**

Designers and Manufacturers  
 18<sup>th</sup> & Bloomingdale Avenue  
 Melrose Park, Illinois 60160  
 U.S.A.

Phone 312-450-2600 (in Illinois)  
 800-323-0257 (elsewhere)  
 Telex 68-710-28 LB·LIN·UW

---

# DESCRIPTION

---

Lab-Line's Orbit Shaking Water Baths provide dependable heating from slightly above ambient to near boiling and variable-speed shaking from 25 to 400 rpm. They are ideal for general laboratory preparation of uniform solutions. The baths are designed with separate heating and shaking controls, so that they can be used as constant temperature baths (only) or as orbiting shakers (only).

A built-in timer controls the duration of the shaking operation from 0 to 60 minutes, or it can be set for constant operation. An analog tachometer shows the rotation speed.

Bath temperature is controlled by hydraulic thermostats -- one for control, the other for overtemperature protection. The heating element itself has a built-in thermostat that acts as a low-water level safety. When the water level falls below 1-1/2" in the tank, this thermostat shuts off power to the heater. The shaker is not affected.

The rugged, molded polyethylene outer body resists chemical spills and will not rust.

A wide selection of shaking platforms and flask clamps are available from your Lab-Line dealer. The Orbit Shaking Water Bath can be adapted for chilling with an optional cooling coil. Other accessories include a gassing hood, stainless steel and acrylic gable covers to control heat loss, and a cart and dolly to add mobility to the unit.

POK114739

POK108685

# SPECIFICATIONS

## SHAKER

Speed Range: 25 to 400 rpm; maximum safe speed for any load will be less than 400 rpm.

Timer Range: 0 to 60 minutes, plus setting for continuous shaking.

## TEMPERATURE CONTROL

Heater: Two 500-watt elements in one heater with low-water shut-off thermostat built in. Thermostat shuts off heater power only when water is lower than 1-1/2".

Thermometer: Partial immersion type; 0 to 110 C in 1-degree increments. The 37, 56 and 100 C temperature marks are highlighted for easy reference.

Thermostats: Hydraulic, one for Control and one for Safety. Stepless control dials.

Accuracy: +/- 0.5 C at 37 C with optional gable cover.

Uniformity: +/- 0.2 C at 37 C with cover (speed set at 50 rpm)

## POWER REQUIREMENTS

Model 3540: 120 VAC, 50/60 Hz, 1200 watts maximum  
 Model 3540-1: 240 VAC, 50 Hz, 1200 watts maximum

## DIMENSIONS

Unit, overall: 28-3/16" L x 21-1/8"W x 17-1/8"H  
 (71.6 x 53.6 x 43.5 cm)

Tank, inside: 16" L x 13-1/2" W x 7-1/2"H  
 (40.6 x 34.3 x 19 cm)

## UNIT WEIGHT

Model 3540: 120 lbs (54.5 kg)  
 Model 3540-1: 125 lbs (56.8 kg)

# FEATURES

## A. FRONT PANEL

1. Power Switch. A two-position switch with the Power Lamp behind it. Lamp is lit when power is "ON", unlit when power is "OFF".
2. Control Thermostat. A hydraulic thermostat controlling power to the heater.
3. Control Thermostat Lamp. Located directly above the Control Thermostat dial, this lamp is lit when power is applied to the heater through the Control Thermostat.
4. Heater Switch. A three-position switch for selecting "LO" heating, "HI" heating, or no heating. The left position ("LO") energizes one 500-watt heating element; the center position is "OFF"; the right position ("HI") energizes both 500-watt heating elements.
5. Safety Thermostat. A hydraulic thermostat, to be set slightly higher than the control thermostat, provides overtemperature control if the control thermostat fails.
6. Safety Thermostat Lamp. Located directly above the Safety Thermostat dial, this lamp is lit when the Safety Thermostat is controlling heat.
7. Speed Control. An ungraduated dial setting the rotational speed of the shaker. Calibrated through the Tachometer described below.
8. Tachometer. Measures the rotational speed of the shaker in rpm (revolutions per minute), calibrated in 10-rpm increments. Speed is measured through a belt-driven slave tachogenerator.
9. Shaker Timer. Can be set for 0 to 60 minutes of shaking in one-minute intervals. A further position sets the unit for constant shaking operation.

Figure 2  
CONTROL PANEL

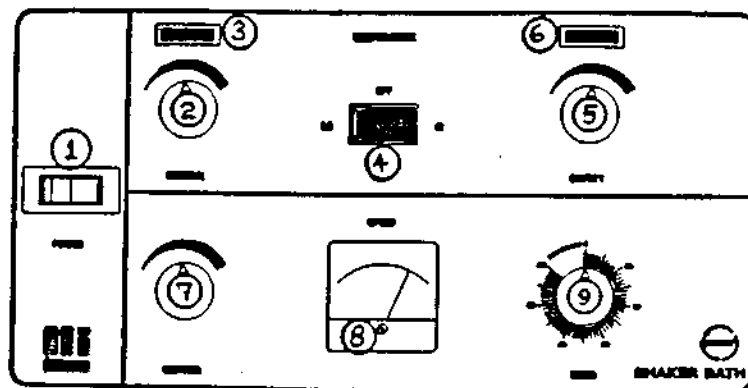

- |                            |                           |                  |
|----------------------------|---------------------------|------------------|
| 1. Power Switch, Lamp      | 4. Heater Switch          | 7. Speed Control |
| 2. Control Thermostat      | 5. Safety Thermostat      | 8. Tachometer    |
| 3. Control Thermostat Lamp | 6. Safety Thermostat Lamp | 9. Shaker Timer  |

## B. TANK TOPSIDE

1. Splash Baffles. Perforated to reduce splashing at high speeds. They are easily removed for cleaning. The front baffle has a grommet to hold the bath thermometer.
2. Thermometer. Mercury-in-glass, partial-immersion type, has a right-angle bend, so it lies flat along the front of the tank. This allows easy reading and reduces the risk of breakage. Range is from 0 to 110 C, marked in 1-degree increments. Three often-used reference points, 37 C, 56 C and 100 C -- are highlighted.
3. Support Arms. Located on the outside of the shaker body and attached to the triple eccentric drive plate to produce the shaking motion. Clamping knobs on top of the Support Arms hold the Suspension Arms in place.
4. Suspension Arms. (four supplied with each unit) attach to the shaking platform and to the support arms. If application demands several platforms to handle different size vessels, order an extra set of suspension arms for each platform to reduce changeover time.
5. Bath Tank. Grade #302 stainless steel with rounded corners to simplify cleaning. Having only two bores through the tank walls (for the heater and thermostat) reduces the risk of leakage and contamination.

Figure 3  
TANK TOPSIDE VIEW

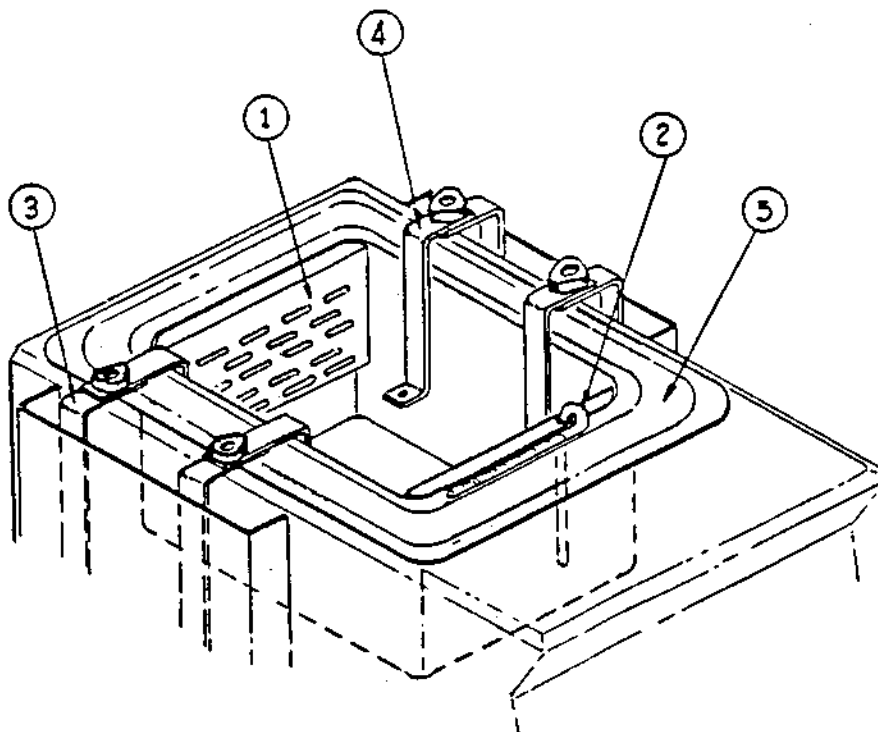

1. Splash Baffles
2. Thermometer
3. Support Arms

4. Suspension Arms
5. Bath Tank